

EC 16 Ø16 mm, brushless, 30 Watt

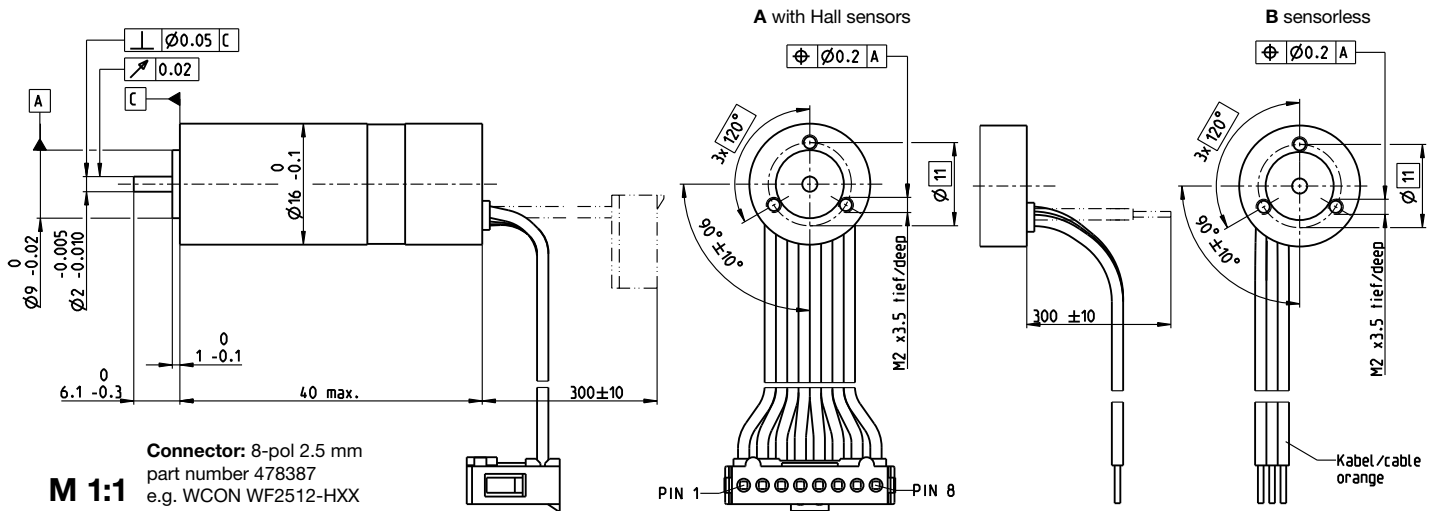

M 1:1
Connector: 8-pol 2.5 mm
 part number 478387
 e.g. WCON WF2512-HXX

- Stock program
- Standard program
- Special program (on request)

		Part Numbers				
	A with Hall sensors	400160	405812	400161	405813	400162
	B sensorless	404079	405817	404080	405818	404081

Motor Data							
Values at nominal voltage							
1	Nominal voltage	V	12	18	24	36	48
2	No load speed	rpm	44500	42200	42800	45800	39600
3	No load current	mA	397	241	185	139	80.8
4	Nominal speed	rpm	39300	37400	38100	41100	34800
5	Nominal torque (max. continuous torque)	mNm	7.85	8.01	8.09	7.56	7.87
6	Nominal current (max. continuous current)	A	3.41	2.18	1.68	1.14	0.754
7	Stall torque	mNm	75.5	78	82.7	82.3	72.5
8	Stall current	A	29.8	19.4	15.6	11.1	6.35
9	Max. efficiency	%	79	80	80	80	79
Characteristics							
10	Terminal resistance phase to phase	Ω	0.403	0.928	1.53	3.24	7.56
11	Terminal inductance phase to phase	mH	0.0235	0.059	0.102	0.2	0.477
12	Torque constant	mNm/A	2.54	4.02	5.29	7.4	11.4
13	Speed constant	rpm/V	3760	2380	1810	1290	836
14	Speed/torque gradient	rpm/mNm	598	549	524	565	554
15	Mechanical time constant	ms	4.54	4.17	3.98	4.29	4.21
16	Rotor inertia	gcm ²	0.725	0.725	0.725	0.725	0.725

Specifications			
Thermal data			
17	Thermal resistance housing-ambient	16.3 K/W	
18	Thermal resistance winding-housing	1.68 K/W	
19	Thermal time constant winding	1.97 s	
20	Thermal time constant motor	240 s	
21	Ambient temperature	-20...+100°C	
22	Max. winding temperature	+155°C	
Mechanical data (preloaded ball bearings)			
23	Max. speed	70000 rpm	
24	Axial play at axial load < 3.5 N	0 mm	
	> 3.5 N	max. 0.14 mm	
25	Radial play	preloaded	
26	Max. axial load (dynamic)	3 N	
27	Max. force for press fits (static) (static, shaft supported)	35 N	
28	Max. radial load, 5 mm from flange	250 N	
10		10 N	

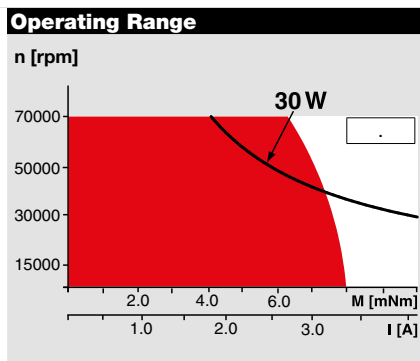

Comments

Continuous operation
 In observation of above listed thermal resistance (lines 17 and 18) the maximum permissible winding temperature will be reached during continuous operation at 25°C ambient.
 = Thermal limit.

Short term operation
 The motor may be briefly overloaded (recurring).

Assigned power rating

Other specifications			
29	Number of pole pairs	1	
30	Number of phases	3	
31	Weight of motor	34 g	

Values listed in the table are nominal.

Connection A		
brown	Motor winding 1	Pin 1
red	Motor winding 2	Pin 2
orange	Motor winding 3	Pin 3
yellow	V _{Hall} 3...24 VDC	Pin 4
green	GND	Pin 5
blue	Hall sensor 1	Pin 6
violet	Hall sensor 2	Pin 7
grey	Hall sensor 3	Pin 8

Wiring diagram for Hall sensors see p. 41

Connection B (Cable AWG 24)		
brown	Motor winding 1	
red	Motor winding 2	
orange	Motor winding 3	

Overview on page 28–36

maxon Modular System			
Planetary Gearhead Ø16 mm 0.1 - 0.6 Nm Page 320/321		Recommended Electronics: Notes Page 32	
Planetary Gearhead Ø22 mm 0.5 - 1.0 Nm Page 325		ESCON Module 24/2	426
Spindle Drive Ø16 mm Page 361–363		ESCON 36/3 EC	427
		ESCON Mod. 50/4 EC-S	427
		ESCON Module 50/5	427
		ESCON 50/5	428
		DEC Module 24/2, 50/5	430
		EPOS2 24/2, Module 36/2	434
		EPOS2 24/5, EPOS2 50/5	435
		EPOS2 P 24/5	438
		EPOS4 Mod./CB 24/1.5	441
		EPOS4 Module/CB 50/5	442
		MAXPOS 50/5	447

for type A:
Encoder MR
 128/256/512 CPT,
 Page 403