

# EC 45 flat $\varnothing 43.5$ mm, brushless, 50 watt

EC flat

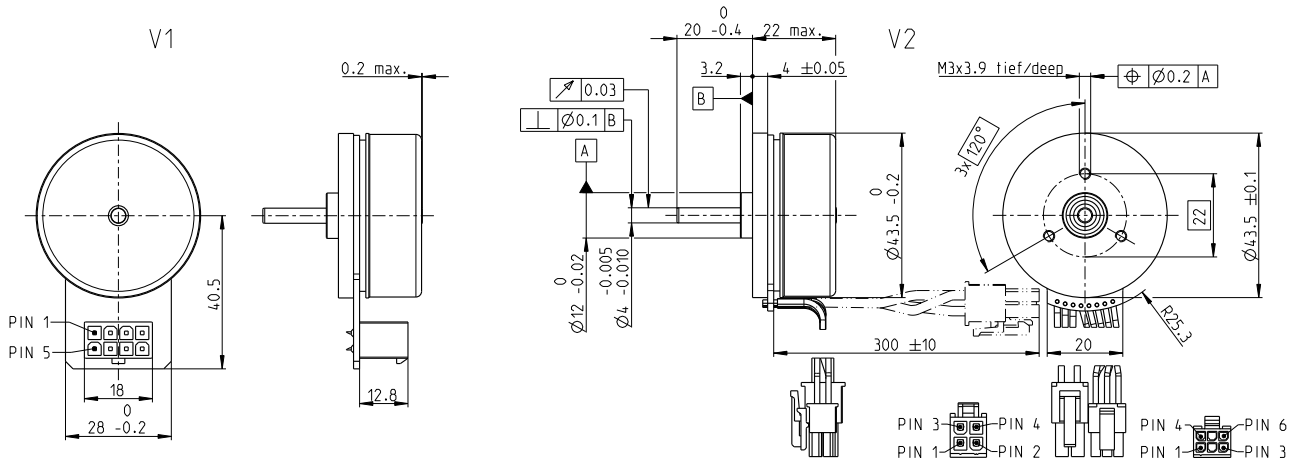

## M 1:2

- Stock program
- Standard program
- Special program (on request)

Part Numbers				
V1 with Hall sensors	651606	651607	651608	651609
V2 with Hall sensors and cables	651610	651611	651612	651613

Motor Data					
Values at nominal voltage					
1 Nominal voltage	V	18	24	36	48
2 No load speed	rpm	5740	6250	6060	5740
3 No load current	mA	277	238	151	104
4 Nominal speed	rpm	4690	5170	5010	4710
5 Nominal torque (max. continuous torque)	mNm	112	91.1	90.9	102
6 Nominal current (max. continuous current)	A	3.68	2.52	1.63	1.27
7 Stall torque <sup>1</sup>	mNm	1190	918	895	1040
8 Stall current	A	40	26	16	13
9 Max. efficiency	%	84.4	82	81.9	83.4
Characteristics					
10 Terminal resistance phase to phase	$\Omega$	0.447	0.942	2.240	3.610
11 Terminal inductance phase to phase	mH	0.243	0.363	0.868	1.730
12 Torque constant	mNm/A	29.5	36	55.7	78.6
13 Speed constant	rpm/V	324	265	171	121
14 Speed/torque gradient	rpm/mNm	4.910	6.920	6.890	5.580
15 Mechanical time constant	ms	6.940	9.790	9.750	7.890
16 Rotor inertia	gcm <sup>2</sup>	135	135	135	135

Specifications	Operating Range	Comments
<b>Thermal data</b> 17 Thermal resistance housing-ambient 1.57 K/W 18 Thermal resistance winding-housing 8.28 K/W 19 Thermal time constant winding 28.8 s 20 Thermal time constant motor 78.3 s 21 Ambient temperature -40...+100°C 22 Max. winding temperature +125°C <b>Mechanical data (preloaded ball bearings)</b> 23 Max. speed 10000 rpm 24 Axial play at axial load < 8.0 N 0 mm > 8.0 N 0.14 mm 25 Radial play preloaded 7.2 N 26 Max. axial load (dynamic) 53 N 27 Max. force for press fits (static) (static, shaft supported) 1000 N 28 Max. radial load, 5 mm from flange 14.5 N	n [rpm] 	<div style="background-color: red; width: 20px; height: 10px; display: inline-block; margin-right: 5px;"></div> <b>Continuous operation</b> In observation of above listed thermal resistance (lines 17 and 18) the maximum permissible winding temperature will be reached during continuous operation at 25°C ambient. = Thermal limit.  <div style="border: 1px solid black; width: 20px; height: 10px; display: inline-block; margin-right: 5px;"></div> <b>Short term operation</b> The motor may be briefly overloaded (recurring).  — <b>Assigned power rating</b>

maxon Modular System		Details on catalog page 46	
<b>Planetary Gearhead</b> $\varnothing 32$ mm 0.75 - 6.0 Nm Page 394/398 <b>Planetary Gearhead</b> $\varnothing 42$ mm 3.0 - 15.0 Nm Page 407 <b>Spur Gearhead</b> $\varnothing 45$ mm 0.5 - 2.0 Nm Page 409		<b>Encoder MILE</b> 256 - 2048 CPT, 2 channels Page 460	<b>Recommended Electronics:</b> Notes Page 460 ESCON Module 24/2 500 ESCON 36/3 EC 501 ESCON Module 50/5 501 ESCON 50/5 503 DEC Module 24/2 505 DEC Module 50/5 505 EPOS4 Micro 24/5 509 EPOS4 Mod./Comp. 24/1.5 510 EPOS4 Mod./Comp. 50/5 510 EPOS4 Comp. 24/5 3-axes 511 EPOS4 50/5 515 EPOS4 Disk 60/8 516 EPOS2 P 24/5 520
Values listed in the table are nominal. <b>Connection V1</b> Pin 1 Hall sensor 1* Pin 2 Hall sensor 2* Pin 3 V <sub>Hall</sub> 3.5...24 VDC Pin 4 Motor winding 3 Pin 5 Hall sensor 3* Pin 6 GND Pin 7 Motor winding 1 Pin 8 Motor winding 2  Pin 1 Motor winding 1 Pin 2 Motor winding 2 Pin 3 Motor winding 3 Pin 4 N.C.	<b>V2 (sensors, AWG 24)</b> Hall sensor 1* Hall sensor 2* Hall sensor 3* GND V <sub>Hall</sub> 3.5...24 VDC N.C.  <b>V2 (motor, AWG 22)</b> Motor winding 1 Motor winding 2 Motor winding 3 N.C.	*Internal pull-up (7...13 k $\Omega$ ) on V <sub>Hall</sub> Wiring diagram for Hall sensors see p. 59 <b>Connector Part number Part number</b> Molex 39-28-1083 43025-0600 Molex 39-01-2040 <b>Connection cable for V1</b> Universal, L = 500 mm <b>339380</b> to EPOS, L = 500 mm <b>354045</b> 21 Ambient temperature -20...+100°C <small><sup>1</sup>Calculation does not include saturation effect (p. 71/178)</small>	