

EC 45 flat $\varnothing 42.8$ mm, brushless, 70 Watt

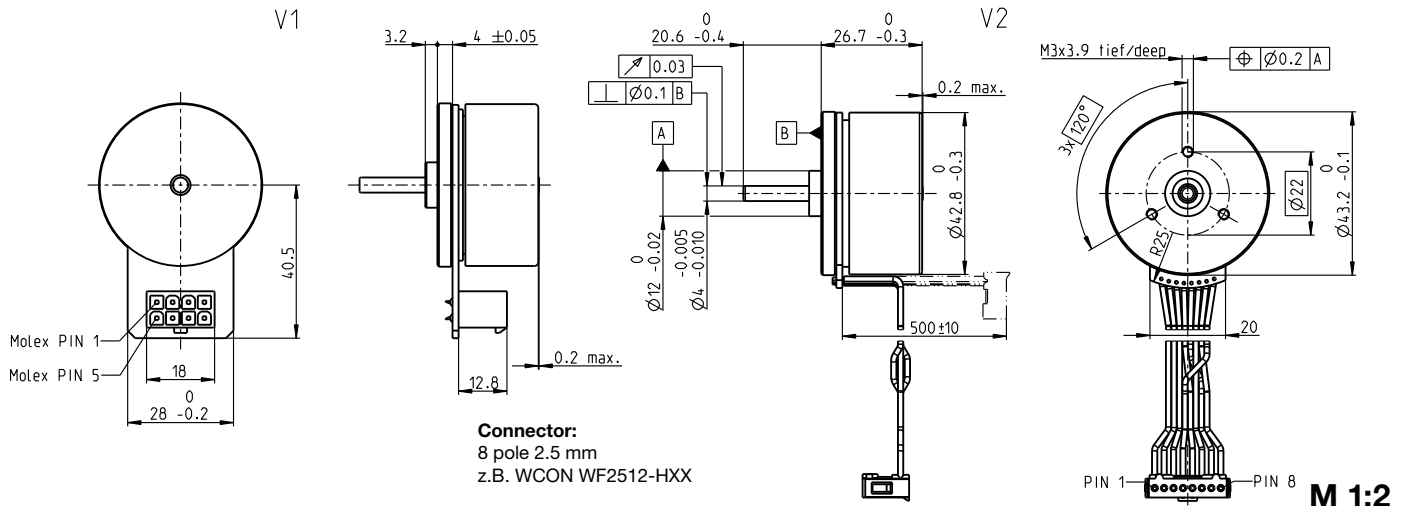

Connector:
8 pole 2.5 mm
z.B. WCON WF2512-HXX

- Stock program
- Standard program
- Special program (on request)

Part Numbers

	397172	402685	402686	402687
V1 with Hall sensors	411812	411814	411815	411816
V2 with Hall sensors and cables	411812	411814	411815	411816

Motor Data (provisional)

Values at nominal voltage		24	30	36	48
1 Nominal voltage	V	24	30	36	48
2 No load speed	rpm	6110	6230	6330	3440
3 No load current	mA	234	194	166	48.1
4 Nominal speed	rpm	4860	4990	5080	2540
5 Nominal torque (max. continuous torque)	mNm	128	112	108	134
6 Nominal current (max. continuous current)	A	3.21	2.36	1.93	0.936
7 Stall torque ¹	mNm	1460	1170	1100	915
8 Stall current	A	39.5	25.8	20.7	6.97
9 Max. efficiency	%	85	84	83	84
Characteristics					
10 Terminal resistance phase to phase	Ω	0.608	1.16	1.74	6.89
11 Terminal inductance phase to phase	mH	0.463	0.691	0.966	5.85
12 Torque constant	mNm / A	36.9	45.1	53.3	131
13 Speed constant	rpm / V	259	212	179	72.7
14 Speed / torque gradient	rpm / mNm	4.26	5.44	5.85	3.82
15 Mechanical time constant	ms	8.07	10.3	11.1	7.24
16 Rotor inertia	gcm ²	181	181	181	181

Specifications

Thermal data	
17 Thermal resistance housing-ambient	3.56 K/W
18 Thermal resistance winding-housing	4.1 K/W
19 Thermal time constant winding	29.6 s
20 Thermal time constant motor	178 s
21 Ambient temperature	-40 ... +100°C
22 Max. winding temperature	+125°C
Mechanical data (preloaded ball bearings)	
23 Max. speed	10000 rpm
24 Axial play at axial load < 4.0 N	0 mm
24 Axial play at axial load > 4.0 N	0.14 mm
25 Radial play	preloaded
26 Max. axial load (dynamic)	3.8 N
27 Max. force for press fits (static) (static, shaft supported)	50 N
27 Max. force for press fits (static) (static, shaft supported)	1000 N
28 Max. radial load, 5 mm from flange	21 N

Other specifications

29 Number of pole pairs	8
30 Number of phases	3
31 Weight of motor	141 g

Values listed in the table are nominal.

Connection V1

Pin	V1	V2 (AWG 24)
Pin 1	Hall sensor 1*	Motor winding 1
Pin 2	Hall sensor 2*	Motor winding 2
Pin 3	V _{hall} 4.5 ... 18 VDC	Motor winding 3
Pin 4	Motor winding 3	V _{hall} 4.5 ... 18 VDC
Pin 5	Hall sensor 3*	GND
Pin 6	GND	Hall sensor 1*
Pin 7	Motor winding 1	Hall sensor 2*
Pin 8	Motor winding 2	Hall sensor 3*

*Internal pull-up (7 ... 13 k Ω) on V_{hall}
Wiring diagram for Hall sensors see p. 47

Cable for V1

Connection cable Universal, L = 500 mm	339380
Connection cable to EPOS, L = 500 mm	354045

V2

21 Ambient temperature	-20 ... +100°C
------------------------	----------------

¹Calculation does not include saturation effect (p. 57/162)

Operating Range

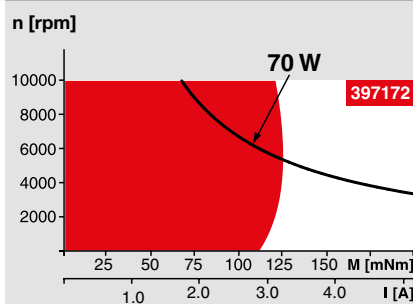

Comments

- Continuous operation**
In observation of above listed thermal resistance (lines 17 and 18) the maximum permissible winding temperature will be reached during continuous operation at 25°C ambient.
= Thermal limit.
- Short term operation**
The motor may be briefly overloaded (recurring).
- Assigned power rating**

maxon Modular System

Details on catalog page 36

Planetary Gearhead

$\varnothing 42$ mm
3 - 15 Nm
Page 363

Spur Gearhead

$\varnothing 45$ mm
0.5 - 2.0 Nm
Page 365

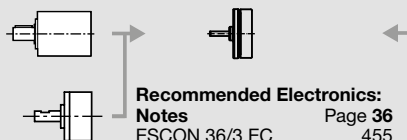

Recommended Electronics:

Notes	Page 36
ESCON 36/3 EC	455
ESCON Mod. 50/4 EC-S	455
ESCON Module 50/5	455
ESCON 50/5	457
DEC Module 50/5	459
EPOS4 50/5	463
EPOS4 Mod./Comp. 50/5	463
EPOS2 P 24/5	470
MAXPOS 50/5	473

Encoder MILE

256 - 2048 CPT,
2 channels
Page 412