

EC 4 Ø4 mm, brushless, 0.5 Watt

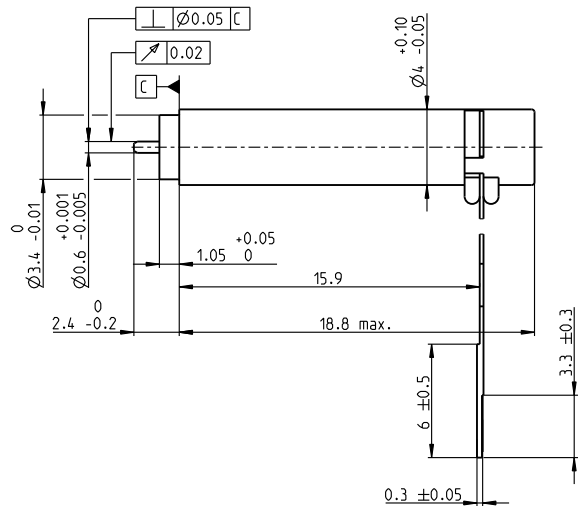
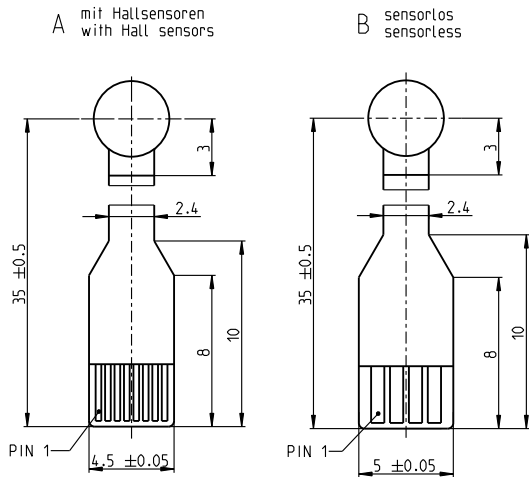

M 5:2

- Stock program
- Standard program
- Special program (on request)

Part Numbers	
A with Hall sensors	431555 431558
B sensorless	423518 423525

Motor Data (provisional)

Values at nominal voltage		3	6
1 Nominal voltage	V	3	6
2 No load speed	rpm	35200	35400
3 No load current	mA	28.8	14.4
4 Nominal speed	rpm	11700	13400
5 Nominal torque	mNm	0.225	0.239
6 Nominal current	A	0.317	0.167
7 Stall torque	mNm	0.355	0.403
8 Stall current	A	0.465	0.264
9 Max. efficiency	%	57	59
Characteristics			
10 Terminal resistance phase to phase	Ω	6.45	22.8
11 Terminal inductance phase to phase	mH	0.0749	0.285
12 Torque constant	mNm/A	0.763	1.53
13 Speed constant	rpm/V	12500	6240
14 Speed/torque gradient	rpm/mNm	106000	92900
15 Mechanical time constant	ms	1.23	1.08
16 Rotor inertia	gcm ²	0.00111	0.00111

Specifications

Thermal data	
17 Thermal resistance housing-ambient	96.7 K/W
18 Thermal resistance winding-housing	15.2 K/W
19 Thermal time constant winding	0.74 s
20 Thermal time constant motor	58.5 s
21 Ambient temperature	-20...+80°C
22 Max. winding temperature	+125°C
Mechanical data	
23 Max. speed	50000 rpm
24 Axial play at axial load	max. 0.06 mm
25 Radial play	0.012 mm
26 Max. axial load (dynamic)	0.1 N
27 Max. force for press fits (static)	10 N
28 Max. radial load, 2 mm from flange	0.2 N

Other specifications

29 Number of pole pairs	1
30 Number of phases	3
31 Weight of motor	1.2 g

Values listed in the table are nominal.

Connection	with hall sensors	sensorless
Pin 1	Motor winding 1	Motor winding 1
Pin 2	Motor winding 2	Motor winding 2
Pin 3	Motor winding 3	Motor winding 3
Pin 4	V _{Hall} 3.8...24 VDC	N.C.
Pin 5	GND	
Pin 6	Hall sensor 1	
Pin 7	Hall sensor 2	
Pin 8	Hall sensor 3	

Connector	Part number	Part number
Molex	52745-0897	52207-0460
FCI	SFV8R-2STBE1HLF	SFW4R-2STGE1LF

Pin for design with Hall sensors:
FPC, 8 pole, pitch 0.5 mm, top contact style
Wiring diagram for Hall sensors see page 45

Operating Range

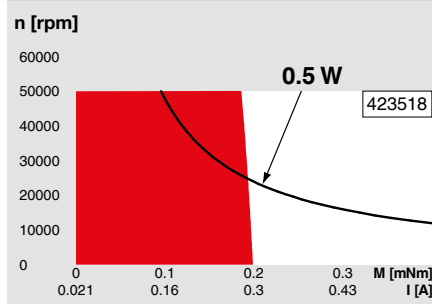

Comments

- Continuous operation**
In observation of above listed thermal resistance (lines 17 and 18) the maximum permissible winding temperature will be reached during continuous operation at 25°C ambient. = Thermal limit.
- Short term operation**
The motor may be briefly overloaded (recurring).
- Assigned power rating**

maxon Modular System

Details on catalog page 34

Planetary Gearhead

Ø4 mm
0.002 - 0.015 Nm
Page 322

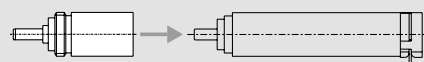

Recommended Electronics:

Notes	Page 34
ESCON Module 24/2	454
ESCON 36/3 EC	455
ESCON Mod. 50/4 EC-S	455