

# EC 6 $\varnothing 6$ mm, brushless, 2 Watt

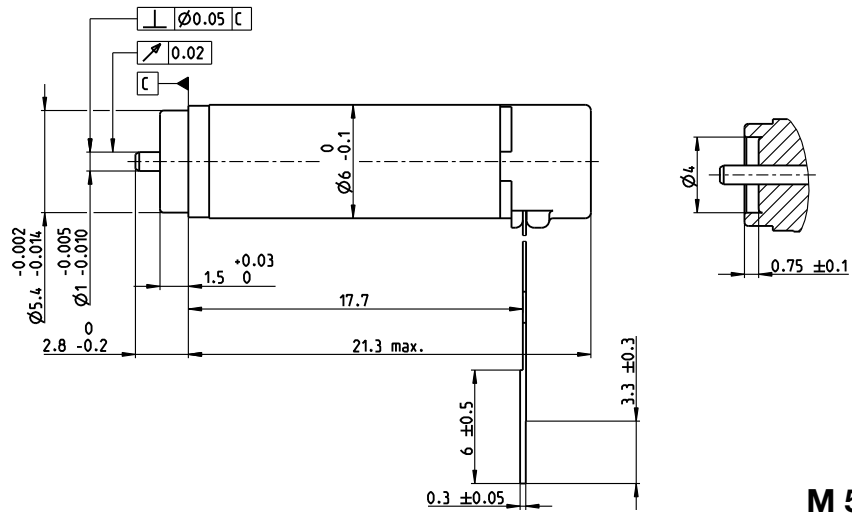
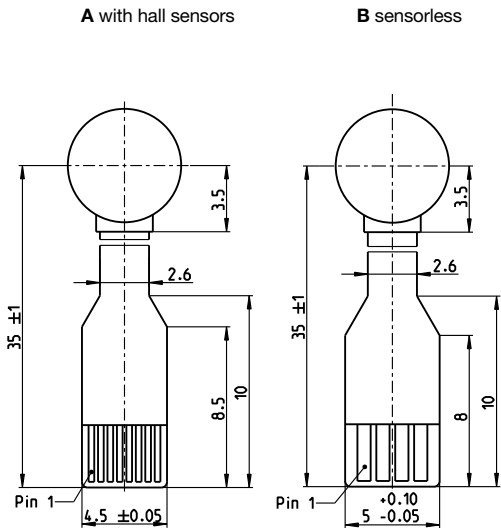

M 5:2

- Stock program
- Standard program
- Special program (on request)

### Part Numbers

A with Hall sensors	455417	455418	455419
B sensorless	455420	455421	455422

### Motor Data (provisional)

Values at nominal voltage		3	6	12
1 Nominal voltage	V	3	6	12
2 No load speed	rpm	74400	62700	63400
3 No load current	mA	149	58.8	29.8
4 Nominal speed	rpm	52300	44900	46800
5 Nominal torque (max. continuous torque)	mNm	0.413	0.412	0.425
6 Nominal current (max. continuous current)	A	1.24	0.517	0.268
7 Stall torque	mNm	1.45	1.52	1.7
8 Stall current	A	3.92	1.72	0.97
9 Max. efficiency	%	66	67	69
Characteristics				
10 Terminal resistance phase to phase	$\Omega$	0.766	3.49	12.4
11 Terminal inductance phase to phase	mH	0.00529	0.0301	0.118
12 Torque constant	mNm/A	0.37	0.882	1.75
13 Speed constant	rpm/V	25800	10800	5460
14 Speed/torque gradient	rpm/mNm	53400	42800	38500
15 Mechanical time constant	ms	3.93	3.15	2.84
16 Rotor inertia	gcm <sup>2</sup>	0.00703	0.00703	0.00703

### Specifications

Thermal data	
17 Thermal resistance housing-ambient	65.8 K/W
18 Thermal resistance winding-housing	13.2 K/W
19 Thermal time constant winding	1.34 s
20 Thermal time constant motor	70.4 s
21 Ambient temperature	-20...+100°C
22 Max. winding temperature	+125°C
Mechanical data (preloaded ball bearings)	
23 Max. speed	100000 rpm
24 Axial play at axial load < 0.15 N	0 mm
24 Axial play at axial load > 0.15 N	max. 0.06 mm
25 Radial play	preloaded
26 Max. axial load (dynamic)	0.1 N
27 Max. force for press fits (static)	10 N
28 Max. radial load, 2 mm from flange	2 N

### Other specifications

29 Number of pole pairs	1
30 Number of phases	3
31 Weight of motor	3 g

Values listed in the table are nominal.

Connection	with hall sensors	sensorless
Pin 1	Motor winding 1	Motor winding 1
Pin 2	Motor winding 2	Motor winding 2
Pin 3	Motor winding 3	Motor winding 3
Pin 4	V <sub>Hall</sub> 3.8...24 VDC	N.C.
Pin 5	GND	
Pin 6	Hall sensor 1	
Pin 7	Hall sensor 2	
Pin 8	Hall sensor 3	
Connector	Part number	Part number
Molex	52745-0897	52207-0460
FCI	SFV8R-2STBE1HLF	SFW4R-2STGE1LF

Pin for design with Hall sensors:  
FPC, 8 pole, pitch 0.5 mm, top contact style  
Wiring diagram for Hall sensors see page 41

### Operating Range

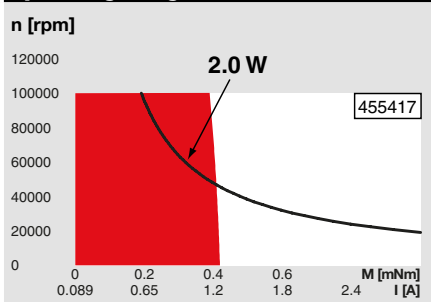

### Comments

- Continuous operation**  
In observation of above listed thermal resistance (lines 17 and 18) the maximum permissible winding temperature will be reached during continuous operation at 25°C ambient. = Thermal limit.
- Short term operation**  
The motor may be briefly overloaded (recurring).
- Assigned power rating**

### maxon Modular System

**Planetary Gearhead**  
 $\varnothing 6$  mm  
0.002 - 0.03 Nm  
Page 317

**Screw Drive**  
 $\varnothing 6$  mm  
Page 365-366

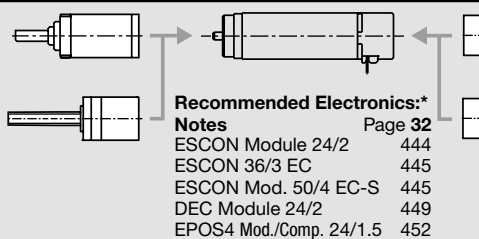

Overview on page 28-36

**Encoder 6 MAG**  
64-256 CPT,  
Page 405

**For motor type B:**  
**Encoder 6 OPT**  
128 CPT,  
Page 421

\*Not in combination with encoder 6 OPT. Adapter acc. to Overview on page 35.