

Planetary Gearhead GP 22 M Ø22 mm, 0.5–2.0 Nm

Sterilizable

maxon gear

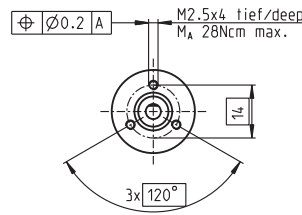
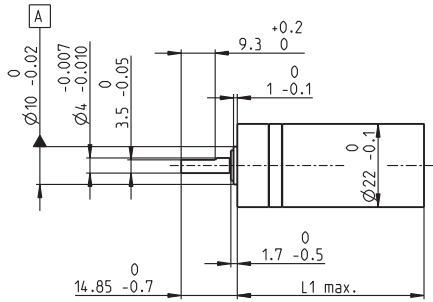

M 1:2

Technical Data

Planetary Gearhead	straight teeth
Output shaft	stainless steel, hardened
Bearing at output	ball bearing
Radial play, 10 mm from flange	max. 0.12 mm
Axial play	max. 0.05 mm
Max. axial load (dynamic)	100 N
Max. force for press fits	100 N
Direction of rotation, drive to output	=
Max. continuous input speed	8000 rpm
Recommended temperature range	0...+80°C
Number of stages	1 2 3 4 5
Max. radial load, 10 mm from flange	20 N 30 N 40 N 40 N 40 N

- Stock program
- Standard program
- Special program (on request)

Part Numbers

	305129	305132	305138	305144	305148	305154	305160	305163	305169	305175	305181
Gearhead Data											
1 Reduction	3.8:1	14:1	53:1	104:1	198:1	370:1	590:1	742:1	1386:1	1996:1	3189:1
2 Absolute reduction	15/4	225/16	3375/64	87723/845	50625/256	10556001/28561	59049/100	759375/1024	158340015/114244	28501027/142805	1594323/500
3 Max. motor shaft diameter mm	4	4	4	3.2	4	3.2	4	4	3.2	3.2	4
Part Numbers	305131	305133	305139	305145	305149	305155	305161	305164	305170	305176	305182
1 Reduction	4.4:1	16:1	62:1	109:1	231:1	389:1	690:1	867:1	1460:1	2102:1	3728:1
2 Absolute reduction	57/13	855/52	12825/208	2187/20	192375/832	263169/676	1121931/1625	2885625/3328	3947535/2704	7105563/3380	30292137/8125
3 Max. motor shaft diameter mm	3.2	3.2	3.2	4	3.2	3.2	3.2	3.2	3.2	3.2	3.2
Part Numbers	305131	305134	305140	305146	305150	305156	305162	305165	305171	305177	305183
1 Reduction	5.4:1	19:1	72:1	128:1	270:1	410:1	850:1	1014:1	1538:1	2214:1	4592:1
2 Absolute reduction	27/5	3249/169	48735/676	41553/325	731025/2704	6561/16	531441/625	10965375/10816	98415/64	177147/80	14348907/3125
3 Max. motor shaft diameter mm	2.5	3.2	3.2	3.2	3.2	4	2.5	3.2	4	4	2.5
Part Numbers		305135	305141	305147	305151	305157		305166	305172	305178	
1 Reduction		20:1	76:1	157:1	285:1	455:1		1068:1	1621:1	2458:1	
2 Absolute reduction		81/4	1215/16	19683/125	18225/64	5000211/10985		273375/256	601662057/371293	135005697/54825	
3 Max. motor shaft diameter mm		4	4	2.5	4	3.2		4	3.2	3.2	
Part Numbers		305136	305142		305152	305158		305167	305173	305179	
1 Reduction		24:1	84:1		316:1	479:1		1185:1	1707:1	2589:1	
2 Absolute reduction		1539/65	185193/2197		2777895/8788	124659/260		41668425/35152	15000633/6788	3365793/1300	
3 Max. motor shaft diameter mm		3.2	3.2		3.2	3.2		3.2	3.2	3.2	
Part Numbers		305137	305143		305153	305159		305168	305174	305180	
1 Reduction		29:1	89:1		333:1	561:1		1249:1	1798:1	3027:1	
2 Absolute reduction		729/25	4617/52		69285/208	2368821/4225		1038825/832	373977/208	63950067/21125	
3 Max. motor shaft diameter mm		2.5	3.2		3.2	3.2		3.2	3.2	3.2	
4 Number of stages	1	2	3	3	4	4	4	5	5	5	5
5 Max. continuous torque Nm	0.5	0.6	1.2	1.2	1.8	1.8	1.8	2.0	2.0	2.0	2.0
6 Max. intermittent torque at gear output Nm	0.8	0.9	1.9	1.9	2.7	2.7	2.7	3.0	3.0	3.0	3.0
7 Max. efficiency %	84	70	59	59	49	49	49	42	42	42	42
8 Weight g	64	77	90	90	103	103	103	116	116	116	116
9 Average backlash no load °	1.0	1.2	1.6	1.6	2.0	2.0	2.0	2.0	2.0	2.0	2.0
10 Mass inertia gcm ²	0.5	0.4	0.4	0.4	0.4	0.4	0.4	0.4	0.4	0.4	0.4
11 Gearhead length L1 mm	35.8	42.6	49.4	49.4	56.2	56.2	56.2	63.0	63.0	63.0	63.0

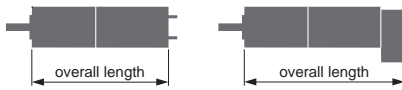

maxon Modular System

+ Motor	Page	+ Sensor/Brake	Page	Overall length [mm] = Motor length + gearhead length + (sensor/brake) + assembly parts									
EC 22, 40 W, ster.	208			80.4	87.2	94.0	94.0	100.8	100.8	107.6	107.6	107.6	107.6
EC 22, 100 W, ster.	210			98.6	105.4	112.2	112.2	119.0	119.0	125.8	125.8	125.8	125.8

Application	Sterilization information
	Without shaft seal: typically 1000 autoclave cycles
Saws	Sterilization with steam
Surgical Reamers	Temperature 134°C ± 4°C
Arthroscopic Shavers	Compression pressure up to 2.3 bar
Surgical Staplers	Rel. humidity 100 %
Dental Tools	Cycle length 18 minutes