

# GPX 42 Ø42 mm, planetary gearhead

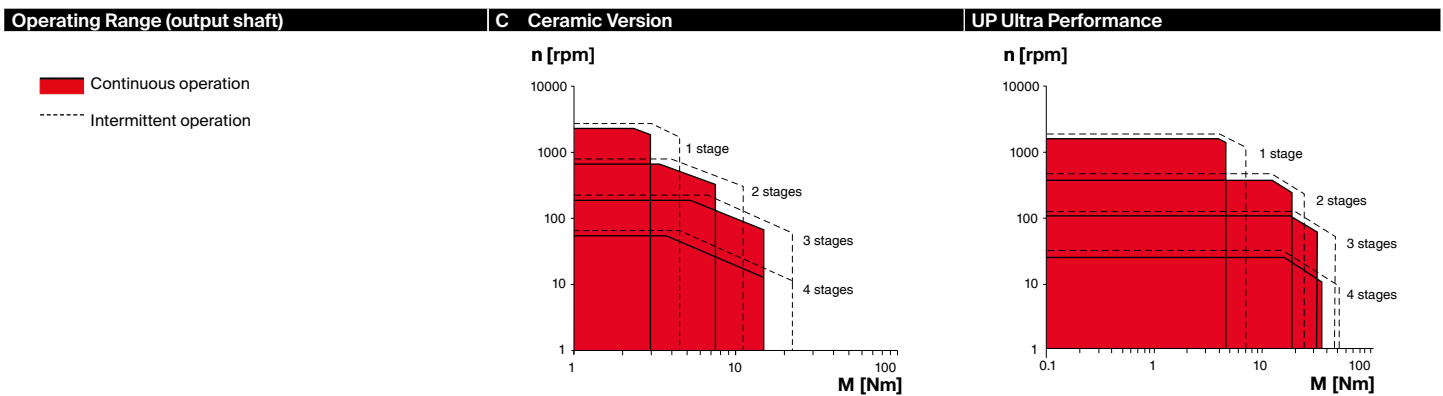

GPX

| Key Data                    | C Ceramic Version | UP Ultra Performance |
|-----------------------------|-------------------|----------------------|
| Max. transmittable power    | W 580             | 650                  |
| Max. continuous torque      | Nm 15.0           | 35.0                 |
| Max. continuous input speed | rpm 8000          | 6000                 |
| Ambient temperature         | °C -40 ... +100   | -40 ... +100         |
| Bearing at output           | Ball bearing      | Ball bearing         |



| Specifications                          | C Ceramic Version           | UP Ultra Performance |
|---|-----------------------------|----------------------|
| Number of stages                        | 1 2 3 4                     | 1 2 3 4              |
| Max. transmittable power (continuous)   | W 580 240 100 20            | 650 460 200 40       |
| Max. transmittable power (intermittent) | W 725 300 125 25            | 820 580 250 50       |
| Max. continuous torque                  | Nm 3.0 7.5 15.0 15.0        | 4.5 18.0 32.0 35.0   |
| Max. intermittent torque                | Nm 4.5 11.3 22.5 22.5       | 7.0 24.0 46.0 50.0   |
| Max. continuous input speed             | rpm 8000 8000 8000 8000     | 6000 6000 6000 6000  |
| Max. intermittent input speed           | rpm 10000 10000 10000 10000 | 7500 7500 7500 7500  |
| Max. efficiency                         | % 90 81 72 64               | 96 93 90 87          |
| Average backlash no load                | ° 0.6 0.8 1.0 1.0           | 0.3 0.4 0.5 0.6      |
| Max. axial load (dynamic)               | N 150 150 150 150           | 200 200 200 200      |
| Max. radial load, 12 mm from flange     | N 120 240 360 360           | 350 525 750 750      |
| Gearhead length L <sup>1</sup>          | mm 37.4 51.9 66.4 80.9      | 48.0 67.0 86.0 104.5 |
| Weight                                  | g 260 360 460 560           | 400 540 660 790      |

| Configuration                    | C Ceramic Version  | UP Ultra Performance  |  |
|----------------------------------|--|---|--|
| Number of stages                 | 1 2 3 4  | 1 2 3 4   |  |
| Reduction                        | X:1 3.5, 4.3 12, 15, 19, 21, 26 43, 53, 66, 74, 81, 113, 126, 156 150, 186, 230, 257, 285, 319, 353, 394, 441, 488, 546, 676, 756, 936 | 3.9, 5.3 16, 21, 26, 28, 35 62, 83, 103, 111, 138, 150, 172, 186, 231 243, 326, 406, 439, 546, 590, 679, 734, 794, 913, 987, 1135, 1227, 1526 |  |
| Absolute reduction: (see online) |  |   |  |
| Version                          | Ceramic version/ultra performance  |   |  |
| Flange                           | Standard flange  |   |  |
| Shaft                            | Length/flat face/feather key   |   |  |

| maxon Modular System | Page                | Dimensions | M 1:2 |
|----------------------|---------------------|------------|-------|
| maxon DC motor       | Nº of stages [opt.] |            |       |
| DCX 35 L             | 1-4                 | 106        |       |

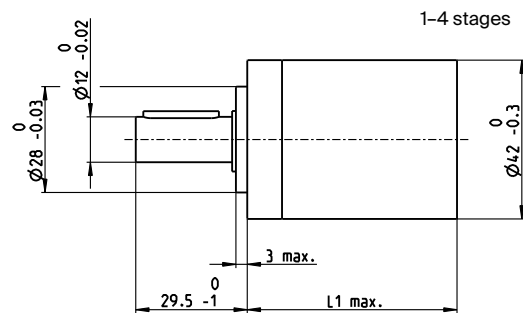

<sup>1</sup>This length may vary depending on the configuration and choice of motor. The effective length is calculated at the end of the configuration process.

gpx.maxongroup.com