

RE 13 Ø13 mm, graphite brushes, 3 watt

RE

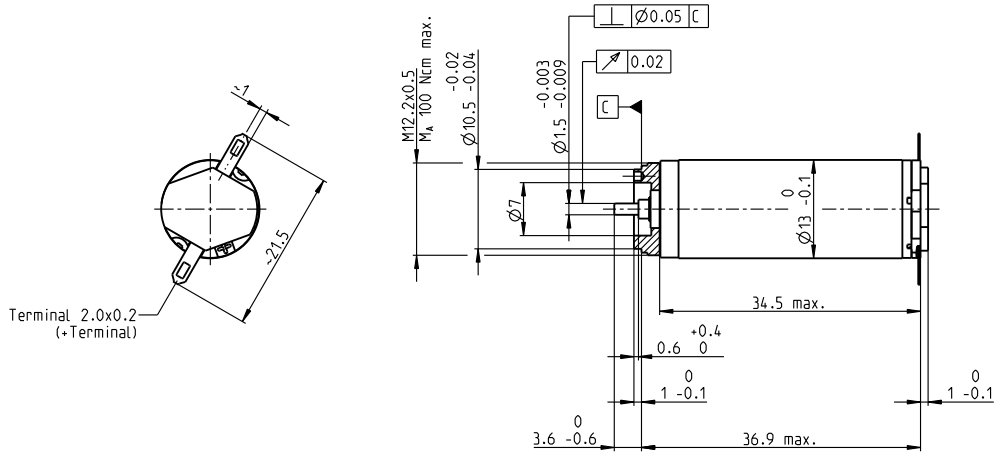

M 1:1

- Stock program
- Standard program
- Special program (on request)

Part Numbers

Motor Data	118597	118598	118599	118600	118601	118602	118603	118604	118605	118606	118607	118608	118609	118610	118611
------------	--------	--------	--------	--------	--------	--------	--------	--------	--------	--------	--------	--------	--------	--------	--------

Motor Data	118597	118598	118599	118600	118601	118602	118603	118604	118605	118606	118607	118608	118609	118610	118611	
Values at nominal voltage																
1 Nominal voltage	V	3	3.6	3.6	4.8	6	6	7.2	9	10	12	15	18	21	24	30
2 No load speed	rpm	12000	13600	11900	13600	13600	12100	13100	13800	13200	13300	13400	13000	14100	13800	14000
3 No load current	mA	168	164	136	121	95.5	81	75.3	64	53.9	45.4	36.8	29.2	28	23.8	19.5
4 Nominal speed	rpm	9520	10800	8780	10100	10300	8660	9790	10600	10100	10200	10400	9910	11100	10800	11000
5 Nominal torque	mNm	1.22	1.32	1.58	1.92	2.05	2.17	2.12	2.17	2.32	2.3	2.31	2.36	2.29	2.33	2.28
6 Nominal current (max. continuous current)	A	0.72	0.72	0.72	0.72	0.602	0.558	0.495	0.422	0.383	0.319	0.259	0.212	0.192	0.167	0.134
7 Stall torque	mNm	7.44	8.13	7.11	8.58	9.25	8.35	9.03	10.1	10.5	10.4	10.5	10.4	11.1	11	10.9
8 Stall current	A	3.46	3.51	2.69	2.73	2.33	1.87	1.82	1.69	1.52	1.25	1.03	0.814	0.809	0.688	0.556
9 Max. efficiency	%	50	53	53	57	60	60	61	63	64	65	65	66	66	66	66
Characteristics																
10 Terminal resistance	Ω	0.867	1.02	1.34	1.76	2.57	3.21	3.96	5.32	6.6	9.56	14.6	22.1	26	34.9	54
11 Terminal inductance	mH	0.021	0.025	0.032	0.046	0.073	0.092	0.114	0.164	0.223	0.316	0.486	0.75	0.871	1.19	1.79
12 Torque constant	mNm/A	2.15	2.31	2.65	3.14	3.97	4.46	4.96	5.95	6.94	8.27	10.2	12.7	13.7	16	19.7
13 Speed constant	rpm/V	4440	4130	3610	3040	2410	2140	1930	1600	1380	1160	932	750	696	595	485
14 Speed / torque gradient	rpm/mNm	1790	1830	1830	1700	1560	1540	1540	1430	1310	1340	1330	1300	1320	1300	1330
15 Mechanical time constant	ms	12.8	11.4	10.5	9.44	8.68	8.46	8.23	7.93	7.74	7.62	7.51	7.42	7.39	7.37	7.38
16 Rotor inertia	gcm ²	0.681	0.596	0.548	0.53	0.53	0.526	0.512	0.528	0.565	0.545	0.541	0.544	0.536	0.543	0.529

Specifications Operating Range Comments

- Thermal data**
- 17 Thermal resistance housing-ambient 33 K/W
 - 18 Thermal resistance winding-housing 7.0 K/W
 - 19 Thermal time constant winding 4.88 s
 - 20 Thermal time constant motor 259 s
 - 21 Ambient temperature -20...+65°C
 - 22 Max. winding temperature +85°C
- Mechanical data (sleeve bearings)**
- 23 Max. speed 16 000 rpm
 - 24 Axial play 0.05 - 0.15 mm
 - 25 Radial play 0.014 mm
 - 26 Max. axial load (dynamic) 0.8 N
 - 27 Max. force for press fits (static) 15 N
 - 28 Max. radial load, 5 mm from flange 1.4 N

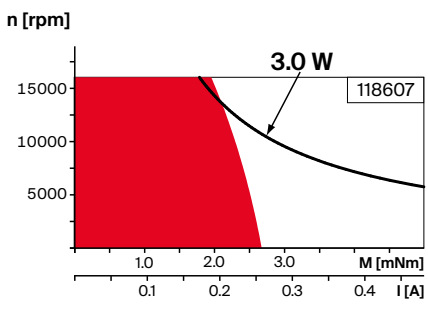

- **Continuous operation**
In observation of above listed thermal resistance (lines 17 and 18) the maximum permissible winding temperature will be reached during continuous operation at 25°C ambient.
= Thermal limit.
- Short term operation**
The motor may be briefly overloaded (recurring).
- **Assigned power rating**

Other specifications 1 Modular System Details on catalog page 44

<p>29 Number of pole pairs 1</p> <p>30 Number of commutator segments 7</p> <p>31 Weight of motor 27 g</p> <p>Values listed in the table are nominal. Explanation of the figures on page 90.</p>	<p>Gear</p> <p>399_GP 13 K</p> <p>400_GP 13 A</p>	<p>Motor Control</p> <p>532_ESCON Module 24/2</p> <p>532_ESCON 36/2 DC</p> <p>533_ESCON Module 50/5</p> <p>535_ESCON 50/5</p>
---	--	--