



■ Features :

- DC/DC step-down converter
- Constant current output: 350mA to 1400mA
- Wide input voltage: 6 ~ 50VDC
Wide output LED string voltage: 3 ~ 45VDC
- High efficiency up to 95%
- Built-in EMI filter, comply with EN55015 without additional input filter and capacitors
- DALI dimming function input under voltage lockout
- Built-in PWM and remote ON/OFF control(pin style only, wire style optional)
- Protections: Short circuit
- Cooling by free air convection
- Fully encapsulated with IP65 level
- Compact size
- Suitable for driving illumination LED
- 3 years warranty



LDD-350H-**W** DA Blank : pin style
 W : wire style

SPECIFICATION

ORDER NO.	LDD-350H-□ DA	LDD-700H-□ DA	LDD-1050H-□ DA	LDD-1400H-□ DA	
OUTPUT	CURRENT RANGE	350mA	700mA	1050mA	
	VOLTAGE RANGE Note.4	3 ~ 45VDC			
	CURRENT ACCURACY (Typ.)	±5% at 48VDC input			
	RIPPLE & NOISE(max.) Note.2	300mVp-p	500mVp-p	500mVp-p	
	SWITCHING FREQUENCY (Typ.)	500KHz			
EXTERNAL CAPACITANCE LOAD (max.)	1400uF				
INPUT	VOLTAGE RANGE	6 ~ 50VDC		6 ~ 40VDC	
	EFFICIENCY (max.)	95% at full load and 48VDC input			
	DC CURRENT	Full load Note.3	275mA	550mA	825mA
		No load	5mA		
FILTER	Capacitor				
PWM DIMMING & ON/OFF CONTROL (PIN STYLE ONLY)	REMOTE ON/OFF	Leave open if not use Power ON with dimming: DIM ~ -Vin >1.2 ~ 5VDC or open circuit, max. operation voltage 5.5VDC Power OFF : DIM ~ -Vin <0.1VDC or short			
	PWM FREQUENCY	200 ~ 1KHz			
	QUIESCENT INPUT CURRENT IN SHUTDOWN MODE(max.)	1mA at PWM dimming OFF and 24VDC input			
ANALOG DIMMING & ON/OFF CONTROL (PIN STYLE ONLY)	REMOTE ON/OFF	Leave open if not use Power ON with dimming: Analog DIM ~ -Vin >0.1 ~ 2.5VDC or open circuit, max. operation voltage 5.5VDC Power OFF : Analog DIM ~ -Vin <0.1VDC or short			
	SHORT CIRCUIT	Regulated at rated output current Protection type: Can be continued, recovers automatically after fault condition is removed			
	INPUT VOLTAGE LOCKOUT	Start up	4.2VDC		
Shut-down		3.8VDC			
ENVIRONMENT	WORKING TEMP.	-40 ~ + 85°C (Refer to derating curve)			
	WORKING HUMIDITY	20% ~ 90% RH non-condensing			
	STORAGE TEMP., HUMIDITY	-55 ~ +125°C, 10 ~ 95% RH non-condensing			
	TEMP. COEFFICIENT	±0.03% / °C			
	VIBRATION	10 ~ 500Hz, 2G 10min./1 cycle, period for 60min. each along X, Y, Z axes			
OPERATING CASE TEMP. (max.)	100°C				
EMC	EMC EMISSION	Compliance to EN55015			
	EMC IMMUNITY	Compliance to EN61547, EN61000-4-2,3,4,6,8, light industry level, criteria A			
OTHERS	MTBF	1.6Mhrs min. MIL-HDBK-217F (25°C)			
	DIMENSION	40.6*23.5*10.1mm or 1.6**0.93**0.40" inch (L*W*H)			
	WEIGHT	LDD-H-DA:18g ; LDD-H-WDA:23g			
	POTTING MATERIAL	Epoxy(UL94-V0)			
NOTE	1.All parameters are specified at normal input(48VDC), rated load, 25°C 70% RH ambient. 2.Ripple & noise are measured at 20MHz by using a 12" twisted pair terminated with a 0.1uf capacitor. 3.Test condition: 48VDC input for 350~1050mA, 28VDC input for 1400mA. 4.Output voltage will always step down by 3 volts from input DC voltage. 5.The output of LDD-H should not be connected to the input of the same unit or output from other sources.				

Mechanical Specification

© Pin style(LDD- 350H~1400H – DA):

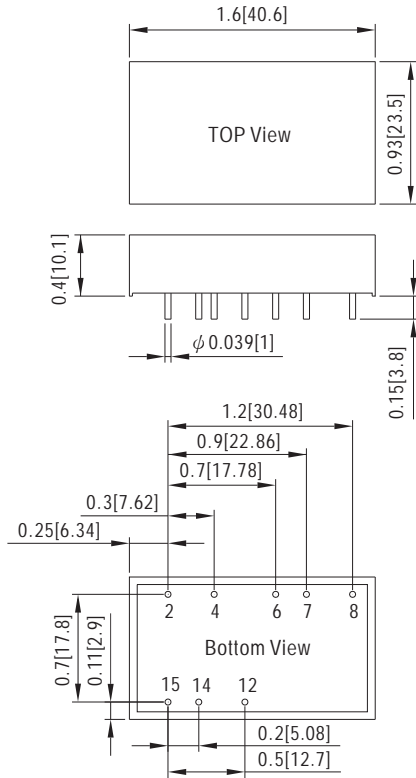

NOTE: Pin tolerance ± 0.05 mm

©Wire style(LDD - 350H~1400H-WDA):

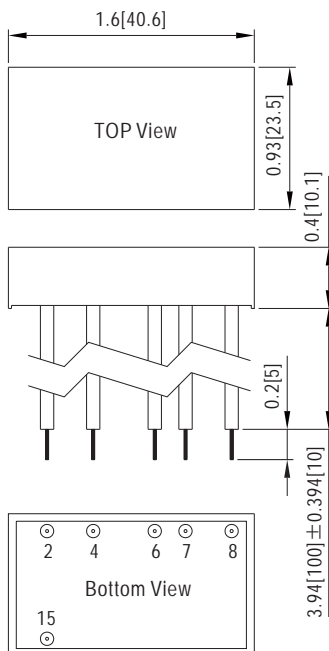

NOTE: Wire range is 16~24AWG

Pin Configuration

Pin No.		Comment
2	+Vin	DC supply
4	+Vout	LED+ connection
6	-Vout	LED- connection
7	DA	Connect to DALI Controller
8	DA	
12	Analogue DIM	Analogue Dimming
14	PWM DIM	PWM Dimming
15	-Vin	DC supply, Don't connect to -Vout

Pin No.		Comment
2	+Vin (Red)	DC supply
4	+Vout (Yellow)	LED+ connection
6	-Vout (Blue)	LED- connection
7	DA (Brown)	Connect to DALI Controller
8	DA (Brown)	
15	-Vin (Black)	DC supply, Don't connect to -Vout

■ PWM Dimming Control & Diagram(pin style only, wire style optional)

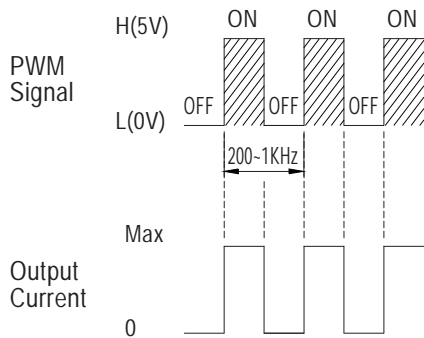

⊙ During PWM dimming operation, the output current will change to PWM style.

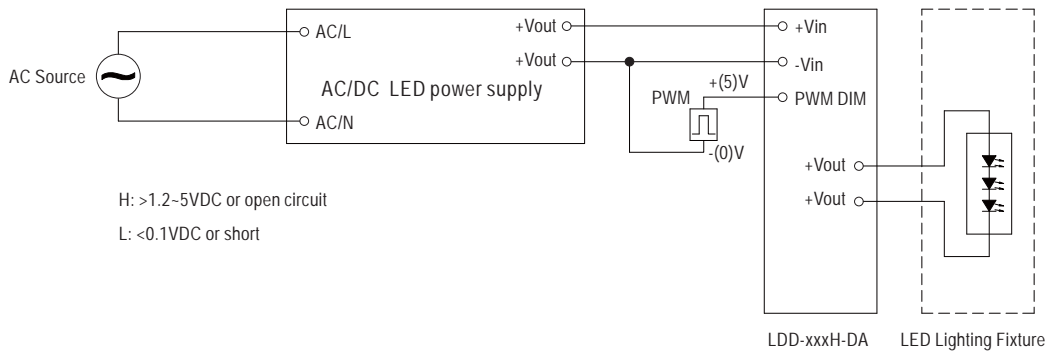
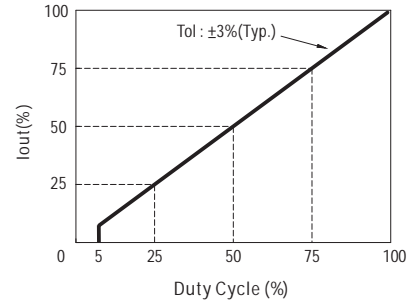

■ Analogue Dimming Control & Diagram(pin style only, wire style optional)

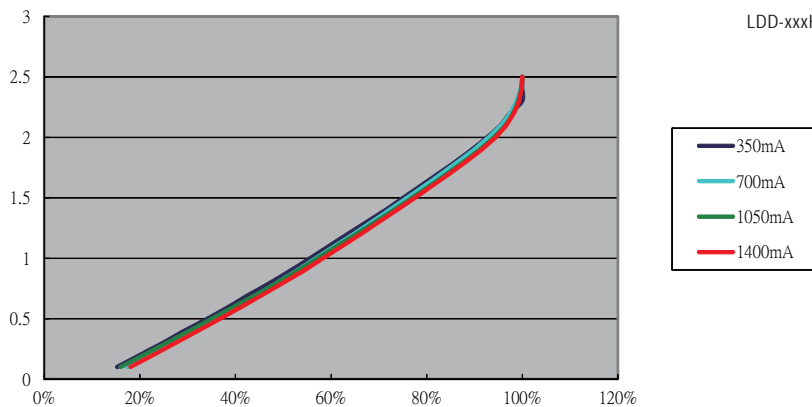
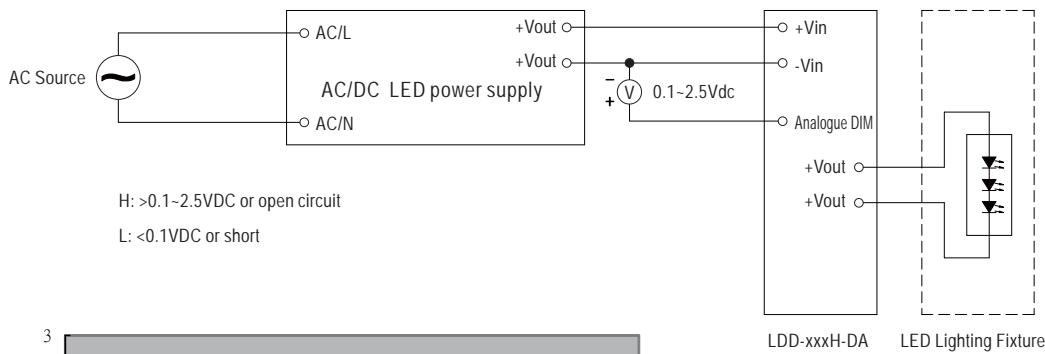

■ Efficiency VS Output Voltage(Number of LEDs)

Fig-1 12VDC input, 1-3 LEDs(Vf=3V)

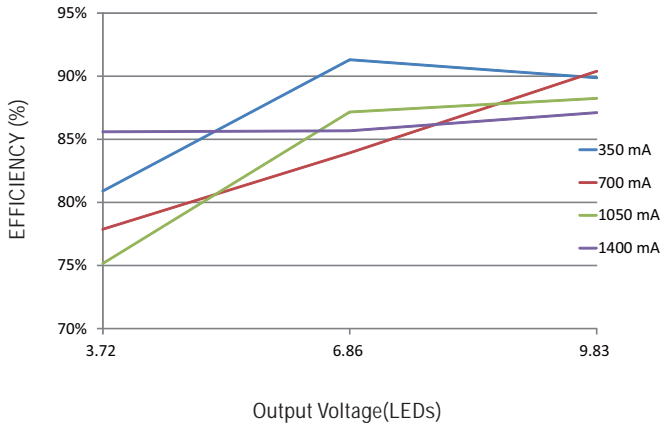

Fig-2 24VDC input, 1-7 LEDs(Vf=3V)

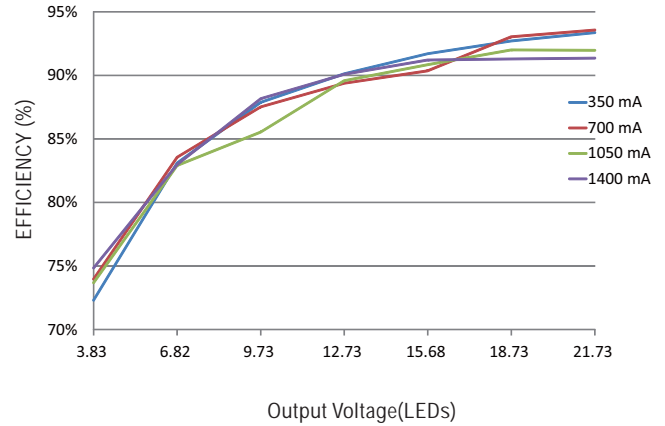

Fig-3 36VDC input, 1-11 LEDs(Vf=3V)

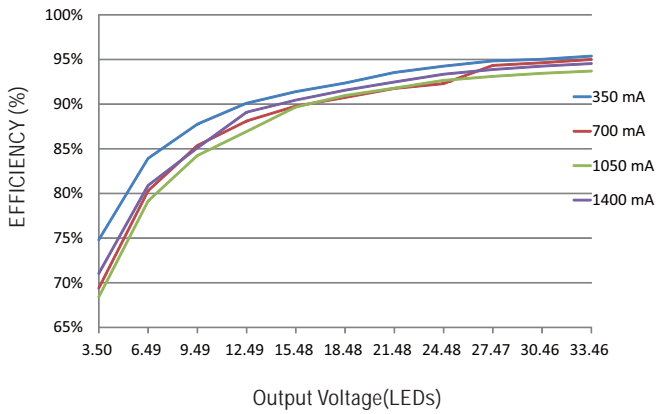
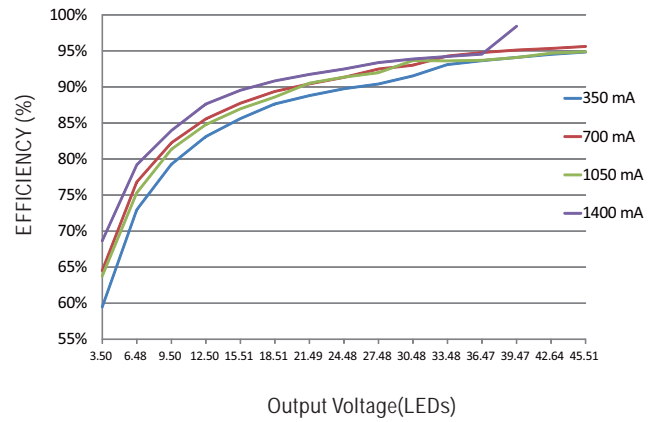

Fig-4 48VDC input, 1-15 LEDs(Vf=3V)



■ Derating Curve

