

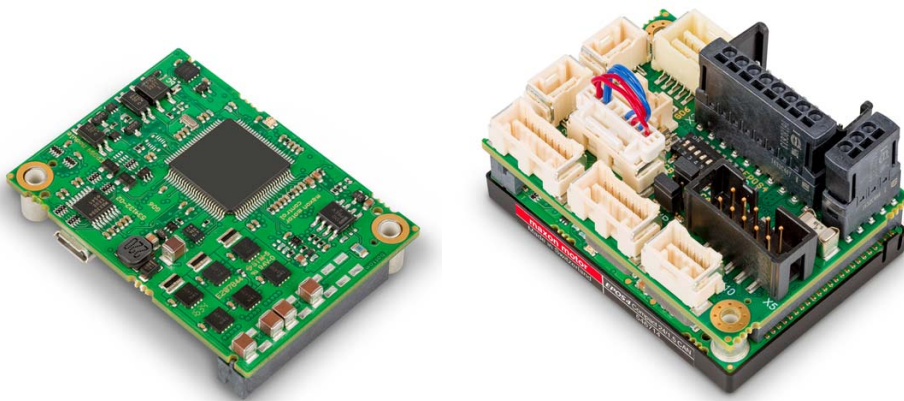
EPOS4 Module 24/1.5

*Positioning Controller
P/N 536630*

EPOS4 Compact 24/1.5 CAN

*Positioning Controller
P/N 546714*

Hardware Reference



epos.maxonmotor.com

Document ID: rel8002

TABLE OF CONTENTS

1	About	5
1.1	About this Document	5
1.2	About the Devices	8
1.3	About the Safety Precautions	10
2	Specifications	11
2.1	Technical Data	11
2.2	Thermal Data	13
2.3	Limitations	14
2.4	Dimensional Drawings	14
2.5	Standards	16
3	Setup	17
3.1	Generally applicable Rules	17
3.2	Pin Assignment for Module Version	18
3.3	Pin Assignment for Connector Boards & Compact Versions	21
3.3.1	EPOS4 CB 24/1.5 CAN (536997) / EPOS4 Compact 24/1.5 CAN (546714)	21
3.3.2	Cabling	21
3.3.3	Tools	22
3.3.4	Connections	23
3.3.5	Adapters for maxon EC motors with Flexprint Cable (FPC)	37
3.3.6	DIP Switch Configuration (SW1)	39
3.3.7	Jumper Configuration (JP1)	42
3.3.8	Spare Parts	42
3.4	Connection Specifications	43
3.4.1	Power Supply	43
3.4.2	Logic Supply	44
3.4.3	Motor	45
3.4.4	Hall Sensor	46
3.4.5	Encoder	47

READ THIS FIRST

These instructions are intended for qualified technical personnel. Prior commencing with any activities...

- you must carefully read and understand this manual and
- you must follow the instructions given therein.

EPOS4 Module 24/1.5 and EPOS4 Compact 24/1.5 positioning controllers are considered as partly completed machinery according to EU Directive 2006/42/EC, Article 2, Clause (g) and are intended to be incorporated into or assembled with other machinery or other partly completed machinery or equipment.

Therefore, you must not put the device into service,...

- unless you have made completely sure that the other machinery fully complies with the EU directive's requirements!
- unless the other machinery fulfills all relevant health and safety aspects!
- unless all respective interfaces have been established and fulfill the herein stated requirements!

3.4.6	Sensor	49
3.4.7	Digital I/Os	60
3.4.8	Safe Torque Off I/Os	64
3.4.9	Analog I/Os	66
3.4.10	Serial Communication Interface (SCI) / RS232	68
3.4.11	CAN Interface	70
3.4.12	Serial Peripheral Interface (SPI)	72
3.4.13	USB (X13)	73
3.5	Status Indicators	74
4	Motherboard Design Guide	75
4.1	Requirements for Components of Third-party Suppliers	76
4.1.1	Socket Headers	76
4.1.2	Supply Voltage	76
4.1.3	Logic Supply Voltage	77
4.1.4	Motor Cables and Motor Chokes	77
4.1.5	RS232 Transceiver	79
4.1.6	Recommended Components and Manufacturers	80
4.2	Design Guidelines	81
4.2.1	Ground	81
4.2.2	Layout	81
4.3	SMT Footprint	82
5	Wiring	83
5.1	Contents	83
5.2	DC Motors (brushed)	85
5.3	EC Motors (BLDC, brushless)	92

••page intentionally left blank••

1 About

1.1 About this Document

1.1.1 Intended Purpose

Use the document to...

- stay safe,
- be fast,
- end up with set up and ready-to-go equipment.

The purpose of the present document is to familiarize you with the EPOS4 Module 24/1.5 and EPOS4 Compact 24/1.5 positioning controllers. It will highlight the tasks for safe and adequate installation and/or commissioning. Follow the described instructions ...

- to avoid dangerous situations,
- to keep installation and/or commissioning time at a minimum,
- to increase reliability and service life of the described equipment.

The present document is part of a documentation set and contains performance data and specifications, information on fulfilled standards, details on connections and pin assignment, and wiring examples. The below overview shows the documentation hierarchy and the interrelationship of its individual parts:

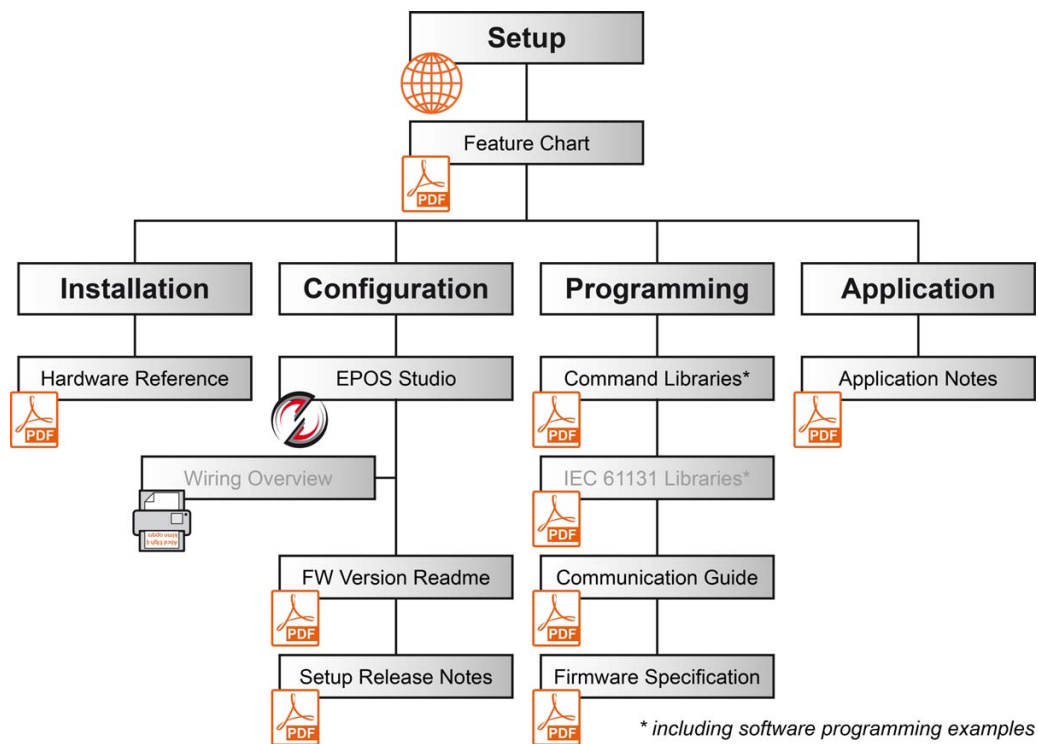


Figure 1-1 Documentation structure

1.1.2 Target Audience

The present document is intended for trained and skilled personnel. It conveys information on how to understand and fulfill the respective work and duties.

1.1.3 How to use

If not stated otherwise, the described details are valid for both the plug-in module and the stand-alone compact version (→ chapter “1.2 About the Devices” on page 1-8).

Throughout the document, the following notations and codes will be used.

Notation	Meaning
(n)	refers to an item (such as part numbers, list items, etc.)
→	denotes “see”, “see also”, “take note of” or “go to”

Table 1-1 Notation used

1.1.4 Symbols & Signs

In the course of the present document, the following symbols and signs will be used.







Type	Symbol	Meaning	
Safety alert	 (typical)	DANGER	Indicates an imminent hazardous situation . If not avoided, it will result in death or serious injury .
		WARNING	Indicates a potential hazardous situation . If not avoided, it can result in death or serious injury .
		CAUTION	Indicates a probable hazardous situation or calls the attention to unsafe practices. If not avoided, it may result in injury .
Prohibited action	 (typical)	Indicates a dangerous action. Hence, you must not!	
Mandatory action	 (typical)	Indicates a mandatory action. Hence, you must!	
Information		Requirement / Note / Remark	Indicates an activity you must perform prior continuing, or gives information on a particular item you need to observe.
		Best practice	Indicates an advice or recommendation on the easiest and best way to further proceed.
		Material Damage	Indicates information particular to possible damage of the equipment.

Table 1-2 Symbols and signs

1.1.5 Trademarks and Brand Names

For easier legibility, registered brand names are listed below and will not be further tagged with their respective trademark. It must be understood that the brands (the list below is not necessarily concluding) are protected by copyright and/or other intellectual property rights even if their legal trademarks are omitted in the later course of this document.

Brand Name	Trademark Owner
Adobe® Reader®	© Adobe Systems Incorporated, USA-San Jose, CA
BiSS	© iC-Haus GmbH, DE-Bodenheim
CANopen® CiA®	© CiA CAN in Automation e.V, DE-Nuremberg
CLIK-Mate™ Micro-Fit™ Mini-Fit Jr.™ Mega-Fit®	© Molex, USA-Lisle, IL
EnDat	© DR. JOHANNES HEIDENHAIN GmbH, DE-Traunreut
EtherCAT®	© EtherCAT Technology Group, DE-Nuremberg, licensed by Beckhoff Automation GmbH, DE-Verl
har-flexicon®	© HARTING AG & Co. KG, DE-Espelkamp
Linux®	© Linus Torvalds (The Linux Foundation, USA-San Francisco CA)
Littelfuse® SMD NANO2®	© Littelfuse Inc., USA-Chicago, IL
Minimodul™	© Lumberg Holding GmbH & Co. KG, DE-Schalksmühle
Windows®	© Microsoft Corporation, USA-Redmond, WA

Table 1-3 Brand names and trademark owners

1.1.6 Copyright

© 2018 maxon motor. All rights reserved.

The present document – including all parts thereof – is protected by copyright. Any use (including reproduction, translation, microfilming, and other means of electronic data processing) beyond the narrow restrictions of the copyright law without the prior approval of maxon motor ag, is not permitted and subject to prosecution under the applicable law.

maxon motor ag
Brünigstrasse 220
P.O.Box 263
CH-6072 Sachseln

Phone +41 41 666 15 00
Fax +41 41 666 16 50
Web www.maxonmotor.com

1.2 About the Devices

Capabilities of the device, included features, and supported motors.

maxon motor control's EPOS4 Module 24/1.5 and EPOS4 Compact 24/1.5 are small-sized, full digital, smart positioning control units. Their high power density allow flexible use for brushed DC and brushless EC (BLDC) motors up to approximately 36 Watts with various feedback options, such as Hall sensors, incremental encoders as well as absolute sensors in a multitude of drive applications.

The devices are specially designed to be commanded and controlled as a slave node in a CANopen network. In addition, the units can be operated via any USB or RS232 (the Module requires an external transceiver) communication port of a Windows or Linux workstation. Moreover, the integrated extension interface allows pooling with optionally available communication interfaces, such as EtherCAT or other additional functionalities.

Latest technology, such as field-oriented control (FOC) and acceleration/velocity feed forward in combination with highest control cycle rates allow sophisticated, ease-of-use motion control.

Thanks to its smart design, the EPOS4 Module 24/1.5 can either be used in combination with EPOS4 CB 24/1.5 connector boards as a compact, integrated solution or be incorporated into customer-specific motherboards for single axis or multi axes motion control systems. The controller is available in the following configurations:

- **EPOS4 Module 24/1.5 (536630)**
Plug-in module for use with maxon motor control EPOS4 connector boards or customer-specific motherboards
- **EPOS4 CB 24/1.5 CAN (536997)**
Connector board for initial commissioning or combination to a compact solution providing all connectors, including CANopen interface
- **EPOS4 Compact 24/1.5 CAN (546714)**
Fully integrated, compact, ready-to-use assembly of plug-in module and CANopen connector board

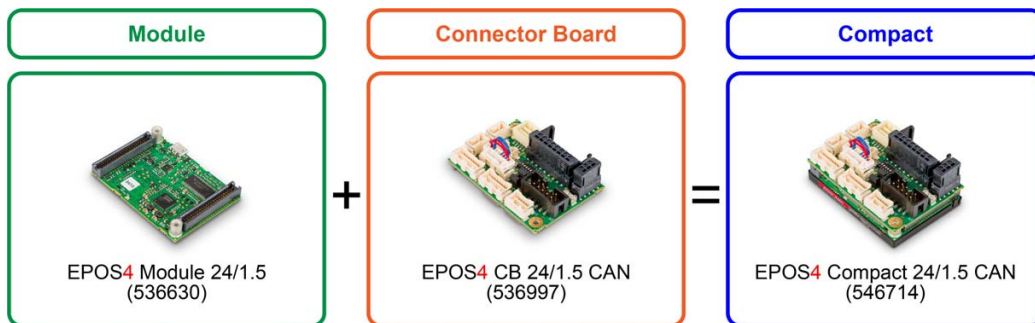


Figure 1-2 Configuration overview

For easier legibility, in the later course of this document naming of components will be as follows:

Short form	Meaning
CB	a connector board (EPOS4 CB 24/1.5 CAN, EPOS4 CB 24/1.5 EtherCAT, available shortly)
Compact	any type of Compact 24/1.5 version
Compact CAN	EPOS4 Compact 24/1.5 CAN
Compact EtherCAT	EPOS4 Compact 24/1.5 EtherCAT (available shortly)
EPOS4	all controller versions (Module and Compact) as well as other EPOS4 positioning controllers as a whole
Module	EPOS4 Module 24/1.5

Table 1-4 Abbreviations

Find the latest edition of the present document as well as additional documentation and software for EPOS4 positioning controllers also on the Internet: →<http://epos.maxonmotor.com>.

In addition, you may wish to browse the EPOS video library. It features video tutorials that provide easy to follow instructions on how to get started with «EPOS Studio» and shows you tips and tricks on how to setup communication interfaces, and so on. Explore on Vimeo: →<https://vimeo.com/album/4646388>



1.3 About the Safety Precautions

Keep in mind:

Safety first! Always!

- Make sure that you have read and understood the note “READ THIS FIRST” on page A-2!
- Do not engage with any work unless you possess the stated skills (→chapter “1.1.2 Target Audience” on page 1-5)!
- Refer to →chapter “1.1.4 Symbols & Signs” on page 1-6 to understand the subsequently used indicators!
- You must observe any regulation applicable in the country and/or at the site of implementation with regard to health and safety/accident prevention and/or environmental protection!



DANGER

High voltage and/or electrical shock

Touching live wires causes death or serious injuries!

- Consider any power cable as connected to live power, unless having proven the opposite!
- Make sure that neither end of cable is connected to live power!
- Make sure that power source cannot be engaged while work is in process!
- Obey lock-out/tag-out procedures!
- Make sure to securely lock any power engaging equipment against unintentional engagement and tag it with your name!



Requirements

- Make sure that all associated devices and components are installed according to local regulations.
- Be aware that, by principle, an electronic apparatus can not be considered fail-safe. Therefore, you must make sure that any machine/apparatus has been fitted with independent monitoring and safety equipment. If the machine/apparatus should break down, if it is operated incorrectly, if the control unit breaks down or if the cables break or get disconnected, etc., the complete drive system must return – and be kept – in a safe operating mode.
- Be aware that you are not entitled to perform any repair on components supplied by maxon motor.



Electrostatic sensitive device (ESD)

- Wear working cloth and use equipment in compliance with ESD protective measures.
- Handle device with extra care.

2 Specifications

2.1 Technical Data

EPOS4 Module 24/1.5 (536630) EPOS4 Compact 24/1.5 CAN (546714)			
Electrical Rating	Nominal power supply voltage $+V_{CC}$	10...24 VDC	
	Nominal logic supply voltage $+V_C$	Module	10...24 VDC
		Compact	10...24 VDC, optional
	Absolute supply voltage $+V_{min} / +V_{max}$	8 VDC / 28 VDC	
	Output voltage (max.)	0.9 x $+V_{CC}$	
	Output current I_{cont} / I_{max} (<30 s)	1.5 A / 4.5 A	
	Pulse Width Modulation frequency	100 kHz	
	Sampling rate PI current controller	25 kHz (40 μ s)	
	Sampling rate PID speed controller	2.5 kHz (400 μ s)	
	Sampling rate PID positioning controller	2.5 kHz (400 μ s)	
	Max. efficiency	89% (→Figure 2-4)	
	Max. speed DC motor	limited by max. permissible speed (motor) and max. output voltage (controller)	
	Max. speed EC motor (block)	100'000 rpm (1 pole pair)	
	Max. speed EC motor (sinusoidal)	50'000 rpm (1 pole pair)	
Built-in motor choke	Module	–	
	Compact	3 x 94 μ H; 1.5 A	
Inputs & Outputs	Digital Input 1 (general purpose) Digital Input 2 (general purpose) Digital Input 3 (general purpose) Digital Input 4 (general purpose)	Module	+2.1...+36 VDC
		Compact	DIP switch-selectable levels: • Logic: +2.0...+30 VDC • PLC: +9.0...+30 VDC
	Digital Output 1 (general purpose) Digital Output 2 (general purpose)	max. 36 VDC / $I_L \leq 500$ mA (open collector with internal pull-up)	
	STO Input 1 STO Input 2	+4.5...+30 VDC (optically isolated)	
	STO Output	max. 30 VDC / $I_L \leq 15$ mA (optically isolated with self-resetting short-circuit protection)	
	Analog Input 1 Analog Input 2	Resolution 12-bit, –10...+10 V, 10 kHz, differential	
	Analog Output 1 Analog Output 2	Resolution 12-bit, –4...+4 V, 25 kHz, referenced to GND	
	Digital Hall sensor signals H1, H2, H3	+2.0...+24 VDC (internal pull-up)	

Continued on next page.

EPOS4 Module 24/1.5 (536630) EPOS4 Compact 24/1.5 CAN (546714)			
Inputs & Outputs (continued)	Digital incremental encoder signals A, A _I , B, B _I , I, I _I	EIA RS422, max. 6.25 MHz	
	Sensor signals (choice between multiple functions) <ul style="list-style-type: none"> • Digital incremental encoder • Analog incremental encoder • SSI absolute encoder • High-speed digital input 1...4 and High-speed digital output 1 	3-channel, EIA RS422, max. 6.25 MHz 3-channel, resolution 12-bit, ±1.8 V, differential configurable, EIA RS422, 5 MHz EIA RS422, max. 6.25 MHz EIA RS422, max. 6.25 MHz	
Voltage Outputs	Sensor supply voltage V_{Sensor}	+5 VDC / $I_L \leq 100$ mA	
	Auxiliary output voltage V_{Aux}	+5 VDC / $I_L \leq 150$ mA	
Motor Connections	DC motor	+ Motor, – Motor	
	EC motor	Motor winding 1, Motor winding 2, Motor winding 3	
Interfaces	RS232	Module	max. 115'200 bit/s; external transceiver necessary
		Compact	max. 115'200 bit/s
	USB 2.0 / USB 3.0	Full Speed	
	CAN	max. 1 Mbit/s	
Status Indicators	Operation	green LED	
	Error	red LED	
Physical	Weight	Module	approx. 17 g
		Compact CAN	approx. 58 g
	Dimensions (L x W x H)	Module	53.8 x 38.8 x 11.1 mm
		Compact CAN	55.0 x 40.0 x 31.1 mm
	Mounting	Module	pluggable female box headers 1.27 mm or mounting holes for M2.5 screws
		Compact	mounting holes for M2.5 screws ³⁾
Environmental Conditions	Temperature	Operation	Module: –30...+60 °C Compact: –30...+45 °C
		Extended range ¹⁾	Module: +60...+73 °C Derating –0.115 A/°C (→Figure 2-3) Compact: +45...+70 °C Derating –0.060 A/°C (→Figure 2-3)
		Storage	–40...+85 °C
	Altitude ²⁾	Operation	0...6'000 m MSL
		Extended range ¹⁾	6'000...10'000 m MSL Derating →Figure 2-3
	Humidity	5...90% (condensation not permitted)	

- 1) Operation within the extended range (temperature and altitude) is permitted. However, a respective derating (declination of output current I_{cont}) as to the stated values will apply.
- 2) Operating altitude in meters above Mean Sea Level, MSL.
- 3) Max. tightening torque 0.16 Nm.

Table 2-5 Technical data

2.2 Thermal Data

2.2.1 Derating of Output Current

Module

Compact

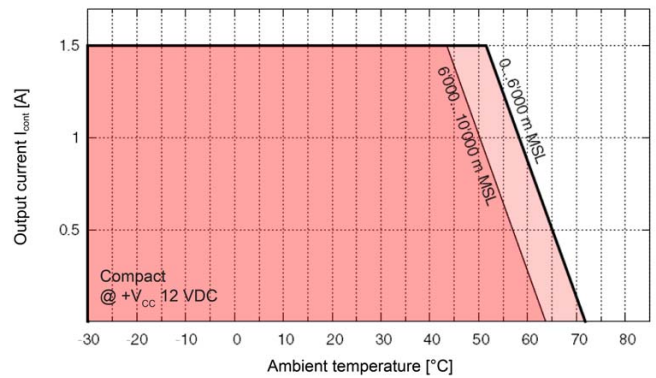
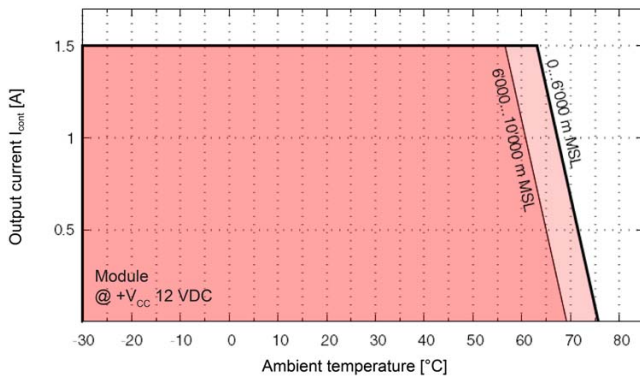
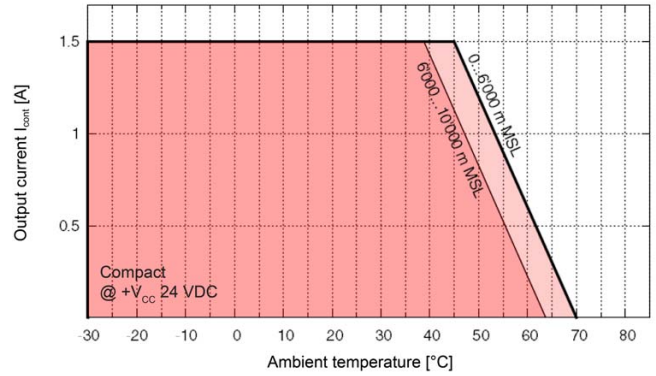
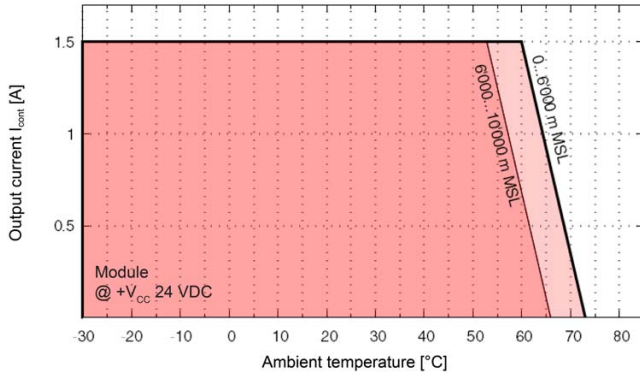


Figure 2-3 Derating of output current

2.2.2 Power Dissipation and Efficiency

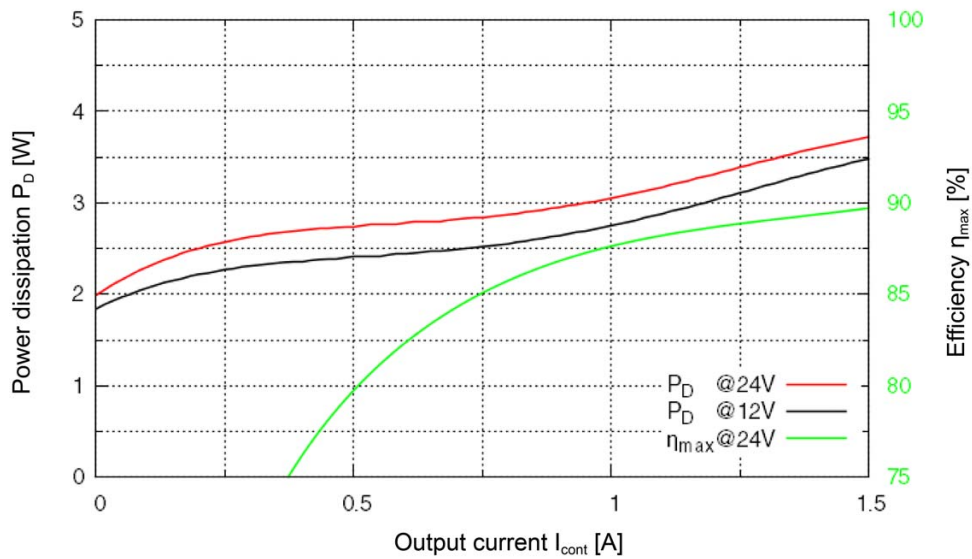


Figure 2-4 Power dissipation and efficiency

2.3 Limitations

Protection functionality	Switch-off threshold	Recovery threshold
Undervoltage	8.0 V	8.5 V
Overvoltage	28 V	27.5 V
Overcurrent	6 A	—
Thermal overload	100 °C	90 °C

Table 2-6 Limitations

2.4 Dimensional Drawings

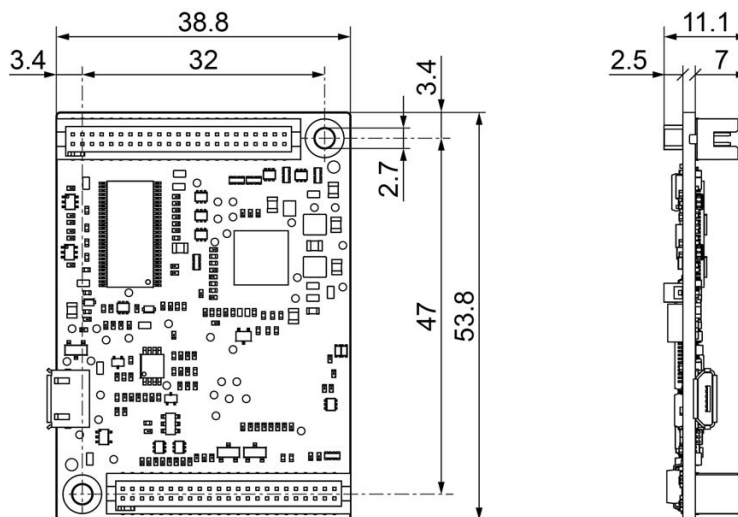


Figure 2-5 EPOS4 Module 24/1.5 – Dimensional drawing [mm]

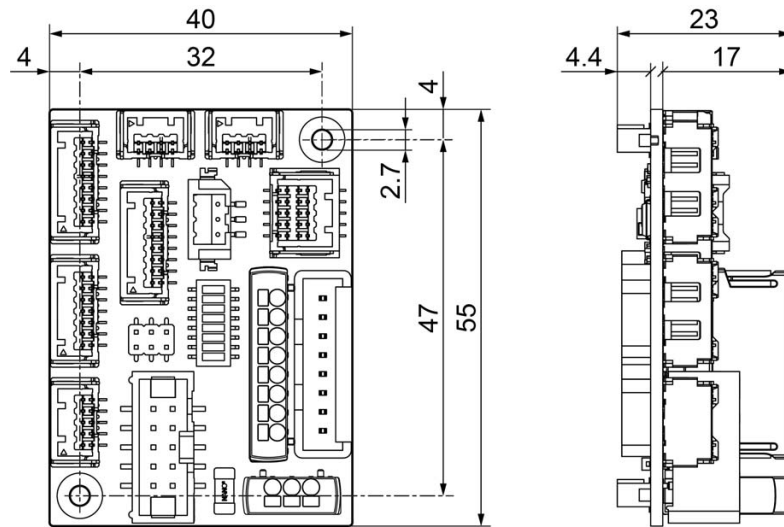


Figure 2-6 EPOS4 CB 24/1.5 CAN – Dimensional drawing [mm]

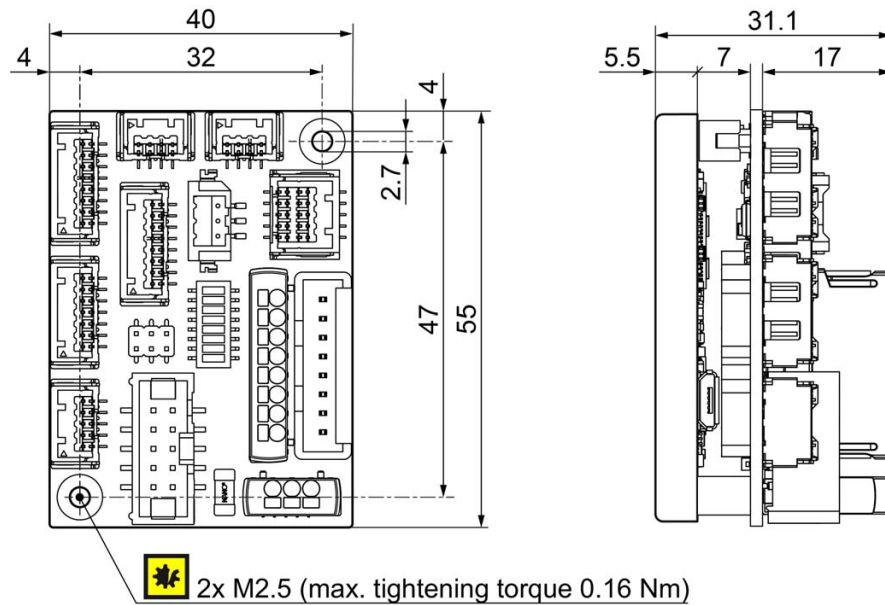


Figure 2-7 EPOS4 Compact 24/1.5 CAN – Dimensional drawing [mm]

2.5 Standards

The described device has been successfully tested for compliance with the below listed standards. In practical terms, only the complete system (the fully operational equipment comprising all individual components, such as motor, servo controller, power supply unit, EMC filter, cabling etc.) can undergo an EMC test to ensure interference-free operation.



Important Notice

The device's compliance with the mentioned standards does not imply its compliance within the final, ready to operate setup. In order to achieve compliance of your operational system, you must perform EMC testing of the involved equipment as a whole.

Electromagnetic Compatibility		
Generic	IEC/EN 61000-6-2	Immunity for industrial environments
	IEC/EN 61000-6-3	Emission standard for residential, commercial and light-industrial environments
Applied	IEC/EN 55022 (CISPR22)	Radio disturbance characteristics / radio interference
	IEC/EN 61000-4-3	Radiated, radio-frequency, electromagnetic field immunity test >10 V/m
	IEC/EN 61000-4-4	Electrical fast transient/burst immunity test ±2 kV
	IEC/EN 61000-4-6	Immunity to conducted disturbances, induced by radio-frequency fields 10 Vrms

Others		
Environment	IEC/EN 60068-2-6	Environmental testing – Test Fc: Vibration (sinusoidal, 10...500 Hz, 20 m/s ²)
	MIL-STD-810F	Random transport (10...500 Hz up to 2.53 g _{rms})
Safety	UL File Number	Unassembled printed circuit board <ul style="list-style-type: none"> • Module: E207844 • Compact CAN: E207844
Reliability	MIL-HDBK-217F	Reliability prediction of electronic equipment Environment: Ground, benign (GB) Ambient temperature: 298 K (25 °C) Component stress: In accordance with circuit diagram and nominal power Mean Time Between Failures (MTBF) <ul style="list-style-type: none"> • Module: 611'610 hours • Compact CAN: 326'977 hours

Table 2-7 Standards

3 Setup

IMPORTANT NOTICE: PREREQUISITES FOR PERMISSION TO COMMENCE INSTALLATION

EPOS4 Module 24/1.5 and EPOS4 Compact 24/1.5 positioning controllers are considered as partly completed machinery according to EU Directive 2006/42/EC, Article 2, Clause (g) and **are intended to be incorporated into or assembled with other machinery or other partly completed machinery or equipment.**

**WARNING****Risk of injury**

Operating the device without the full compliance of the surrounding system with the EU Directive 2006/42/EC may cause serious injuries!

- Do not operate the device, unless you have made completely sure that the other machinery fully complies with the EU directive's requirements!
- Do not operate the device, unless the other machinery fulfills all relevant health and safety aspects!
- Do not operate the device, unless all respective interfaces have been established and fulfill the requirements stated in this document!

3.1 Generally applicable Rules

**Maximal permitted supply voltage**

- Make sure that supply power is between 10...24 VDC.
- Supply voltages above 28 VDC, or wrong polarity will destroy the unit.
- Note that the necessary output current is depending on the load torque. Yet, the output current limits are as follows:
 - continuous max. 1.5 A
 - short-time (acceleration) max. 4.5 A

**Hot plugging the USB interface may cause hardware damage**

If the USB interface is being hot-plugged (connecting while the power supply is on), the possibly high potential differences of the two power supplies of controller and PC/Notebook can lead to damaged hardware.

- Avoid potential differences between the power supply of controller and PC/Notebook or, if possible, balance them.
- Insert the USB connector first, then switch on the power supply of the controller.

3.2 Pin Assignment for Module Version

For in-depth details on connections → chapter “3.4 Connection Specifications” on page 3-43.

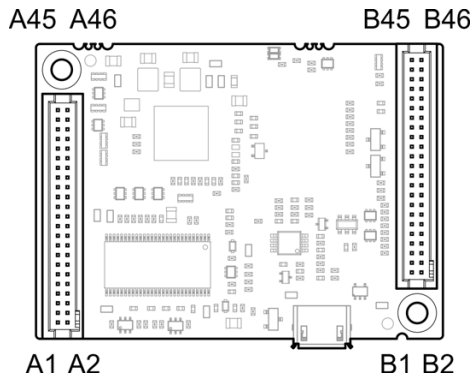


Figure 3-8 Pin assignment

Pin	Signal	Description
A1...A7**	Motor (+M) Motor winding 1	DC motor: Motor + EC motor: Winding 1
A8...A14**	Motor (-M) Motor winding 2	DC motor: Motor - EC motor: Winding 2
A15...A21**	Motor winding 3	EC motor: Winding 3
A22	+V _C	Logic supply voltage (+10...+24 VDC)
A23...A29**	+V _{CC}	Power supply voltage (+10...+24 VDC)
A30...A36**	GND	Ground
A37	Hall sensor 1	Hall sensor 1 input
A38	Hall sensor 2	Hall sensor 2 input
A39	Hall sensor 3	Hall sensor 3 input
A40	V _{Sensor}	Sensor supply voltage (+5 VDC; I _L ≤100 mA)
A41	Channel A	Digital incremental encoder channel A
A42	Channel A\	Digital incremental encoder channel A complement
A43	Channel B	Digital incremental encoder channel B
A44	Channel B\	Digital incremental encoder channel B complement
A45	Channel I	Digital incremental encoder channel I
A46	Channel I\	Digital incremental encoder channel I complement
** Connect all pins in respect to the individual pin current rating.		

Table 3-8 Pin assignment A1...A46 (X1...X5)

Pin	Signal	Description
B1	DigIN1	Digital input 1
B2	DigIN2	Digital input 2
B3	DigIN3	Digital input 3
B4	DigIN4	Digital input 4
B5	DigOUT1	Digital output 1
B6	DigOUT2	Digital output 2
B7	Channel A HsDigIN1	Digital/analog incremental encoder channel A High-speed digital input 1
B8	Channel A\ HsDigIN1\ 	Digital/analog incremental encoder channel A complement High-speed digital input 1 complement
B9	Channel B HsDigIN2	Digital/analog incremental encoder channel B High-speed digital input 2
B10	Channel B\ HsDigIN2\ 	Digital/analog incremental encoder channel B complement High-speed digital input 2 complement
B11	Channel I HsDigIN3 Clock HsDigOUT1	Digital/analog incremental encoder channel I High-speed digital input 3 Clock (SSI) High-speed digital output 1
B12	Channel I\ HsDigIN3\ Clock\ HsDigOUT1\ 	Digital/analog incremental encoder channel I complement High-speed digital input 3 complement Clock (SSI) complement High-speed digital output 1 complement
B13	Data HsDigIN4	Data (SSI) High-speed digital input 4
B14	Data\ HsDigIN4\ 	Data (SSI) complement High-speed digital input 4 complement
B15	V _{Aux}	Auxiliary output voltage (+5 VDC; I _L ≤150 mA)
B16	GND	Ground
B17	STO-IN1+	Safe Torque Off input 1, positive signal
B18	STO-IN1-	Safe Torque Off input 1, negative signal
B19	STO-IN2+	Safe Torque Off input 2, positive signal
B20	STO-IN2-	Safe Torque Off input 2, negative signal
B21	STO-OUT+	Safe Torque Off output, positive signal
B22	STO-OUT-	Safe Torque Off output, negative signal
B23	AnIN1+	Analog input 1, positive signal
B24	AnIN1-	Analog input 1, negative signal
B25	AnIN2+	Analog input 2, positive signal
B26	AnIN2-	Analog input 2, negative signal
B27	AnOUT1	Analog output 1
B28	AnOUT2	Analog output 2
B29	CAN ID 1	CAN ID 1 (valence = 1)
B30	CAN ID 2	CAN ID 2 (valence = 2)

Continued on next page.

Setup

Pin Assignment for Module Version

Pin	Signal	Description
B31	CAN ID 3	CAN ID 3 (valence = 4)
B32	CAN ID 4	CAN ID 4 (valence = 8)
B33	CAN ID 5	CAN ID 5 (valence = 16)
B34	Auto bit rate	Automatic bit rate detection of CAN bus
B35	CAN high	CAN high bus line
B36	CAN low	CAN low bus line
B37...B38	GND	Ground
B39 ⁴⁾	DSP_RxD	Serial communication interface receive (UART)
B40	DSP_TxD	Serial communication interface transmit (UART)
B41 ⁵⁾	SPI_CLK	Serial Peripheral Interface clock
B42 ⁵⁾	SPI_IRQ	Serial Peripheral Interface interrupt request
B43 ⁵⁾	SPI_SOMI	Serial Peripheral Interface Slave output, Master input
B44 ⁵⁾	SPI_SIMO	Serial Peripheral Interface Slave input, Master output
B45 ⁵⁾	SPI_CS2	Serial Peripheral Interface chip select 2
B46 ⁵⁾	SPI_CS1	Serial Peripheral Interface chip select 1
4) connect to sensor supply voltage V_{Sensor} (A40) when RS232 is not in use 5) only used for maxon extension modules		

Table 3-9 Pin assignment B1...B46 (X6...X12)

3.3 Pin Assignment for Connector Boards & Compact Versions

As an alternative to developing an own motherboard, ready-made connector boards are available to combine the Module to Compact versions. They comprise all required connections. For in-depth details on connections → chapter “3.4 Connection Specifications” on page 3-43.

3.3.1 EPOS4 CB 24/1.5 CAN (536997) / EPOS4 Compact 24/1.5 CAN (546714)

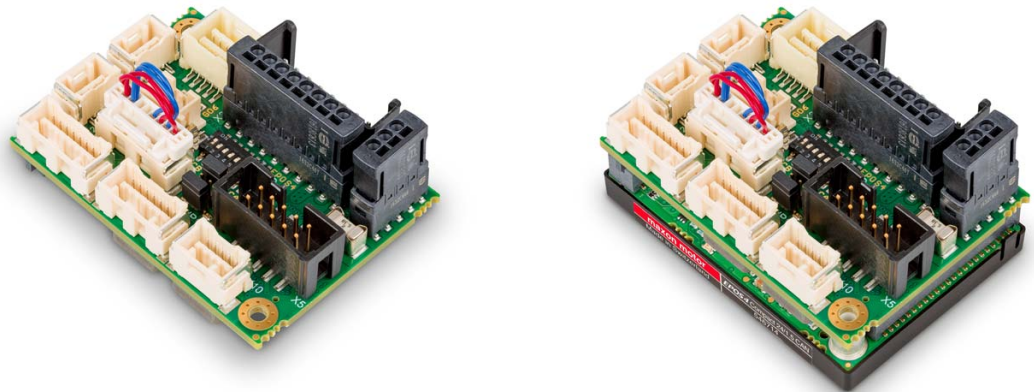


Figure 3-9 EPOS4 CB 24/1.5 CAN (left) / EPOS4 Compact 24/1.5 CAN (right)

3.3.2 Cabling

PLUG&PLAY

Take advantage of maxon’s prefab cable assemblies and adapters. They come as ready-to-use parts and will help to reduce commissioning time to a minimum.

- a) Check the following table and find the part number of the cable assembly or adapter that matches the setup you will be using.
- b) Follow the cross-reference to get the cable’s pin assignment.

Connector	Prefab Cable Assembly & Adapter		
	Designation	Part Number	→Page
X3b/X4b	Adapter BLACK FPC11poles	418719	3-37
	Adapter BLUE FPC8poles	418723	3-38
	Adapter GREEN FPC8poles	418721	3-38
X5	Encoder Cable	275934	3-29
X6	Sensor Cable 5x2core	520852	3-31
X7	Signal Cable 8core	520853	3-32
X8	Signal Cable 7core	520854	3-33
X9	Signal Cable 8core	520853	3-32
X10	RS232-COM Cable	520856	3-35
X11	CAN-COM Cable	520857	3-36
	CAN-CAN Cable	520858	3-36

Continued on next page.

Connector	Prefab Cable Assembly & Adapter		
	Designation	Part Number	→Page
X12	CAN-COM Cable	520857	3-36
	CAN-CAN Cable	520858	3-36
X13	USB Type A - micro B Cable (located at the Module)	403968	3-73

Table 3-10 Prefab maxon cables

MAKE&BAKE YOUR OWN

If you decide not to employ maxon motor's prefab cable assemblies, you might wish to use the prepackaged kit that contains all connectors required to make up your own cabling.

EPOS4 Connector Set (520859)		
Connector	Specification	Quantity
Connectors		
	Molex Mega-Fit, 2 poles (171692-0102)	1
	Molex Mini-Fit Jr., 2 poles (39-01-2020)	2
	Molex Mini-Fit Jr., 4 poles (39-01-2040)	1
	Molex Mega-Fit, 4 poles (171692-0104)	1
	Molex Micro-Fit 3.0, 6 poles (430-25-0600)	1
X6	Molex CLIK-Mate, dual row, 10 poles (503149-1000)	1
X7 / X9	Molex CLIK-Mate, single row, 8 poles (502578-0800)	2
X8	Molex CLIK-Mate, single row, 7 poles (502578-0700)	1
X10	Molex CLIK-Mate, single row, 5 poles (502578-0500)	1
X11 / X12	Molex CLIK-Mate, single row, 4 poles (502578-0400)	2
Crimp Terminals		
	Molex Mega-Fit, female crimp terminal (172063-0311)	7
	Molex Mini-Fit Jr. female crimp terminal (45750-1111)	9
	Molex Micro-Fit 3.0 female crimp terminal (43030-0010)	7
X6...X12	Molex CLIK-Mate crimp terminal (502579-0100)	44
Accessories		
X5	3M Retainer Clip with strain relief, height 13.5 mm (3505-8110)	1

Table 3-11 EPOS4 Connector Set – Content

3.3.3 Tools

Tool	Manufacturer	Part Number
Hand crimper for 3111 crimp contacts	Lumberg	CZ31
Hand crimper for CLIK-Mate crimp terminals	Molex	63819-4600
Hand crimper for DF3 crimp contacts	Hirose	DF3-TA22HC

Table 3-12 Recommended tools

3.3.4 Connections

The USB interface (X13) is located at the Module.

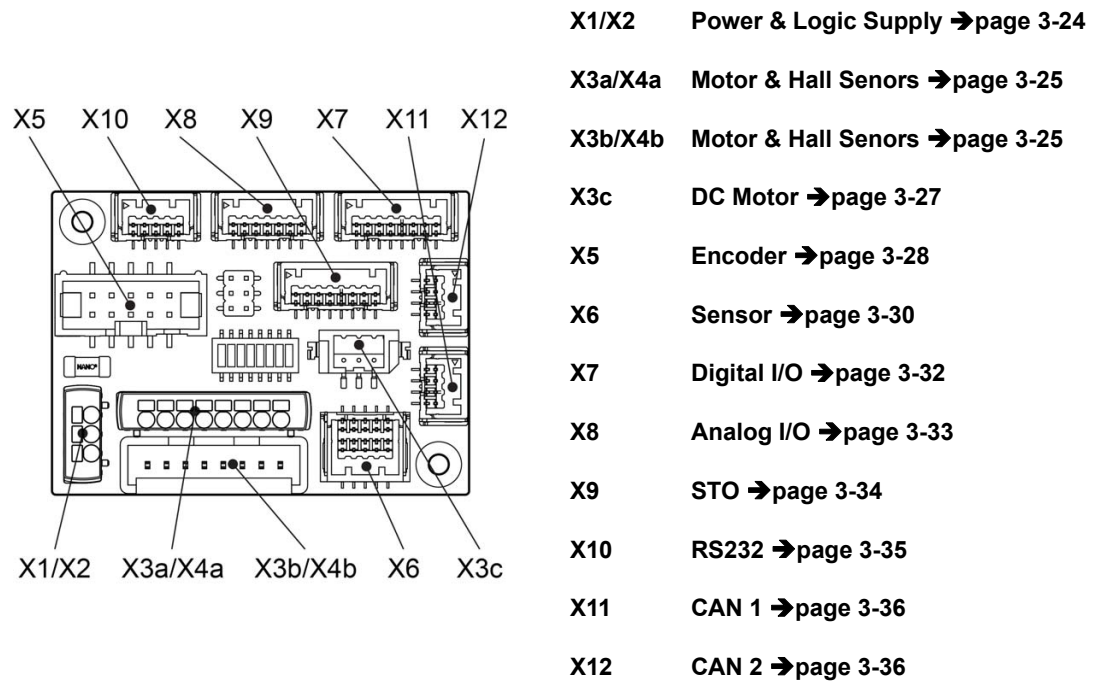


Figure 3-10 EPOS4 CB 24/1.5 CAN – Connectors



How to read pin assignment tables

- The first column describes both the pin number of the connector and of the matching prefab maxon cable's Head A.
- The second column describes the cable core color of the prefab maxon cable.
- The third column describes the pin number of the prefab maxon cable's Head B.

3.3.4.1 Power & Logic Supply (X1/X2)



Best practice

Keep the motor mechanically disconnected during the setup and adjustment phase.

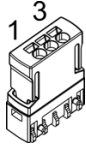


Figure 3-11 Power & logic supply connector X1/X2

X1/X2 Head A Pin	Prefab Cable Color	Head B Pin	Signal	Description
1		–	GND	Ground
2		+	+V _{CC}	Power supply voltage (+10...+24 VDC)
3		+	+V _C	Logic supply voltage (+10...+24 VDC)

Table 3-13 Power & logic supply connector X1/X2 – Pin assignment

Power & Logic Supply Connector X1/X2 (590736)		
Type	Spring-loaded contacts, 3 poles, pitch 2.54 mm	
Suitable plug	Harting har-flexicon 2.54 FPV-3 BK (14 31 031 3101 000) —included with every Compact version delivery—	
Suitable cables	Rigid	0.14...0.5 mm ² , AWG 26-20 / wire stripping length 6 mm
	Flexible	0.2...0.5 mm ² , AWG 24-20 / wire stripping length 6 mm 0.25...0.34 mm ² , AWG 24-22 / wire stripping length 6 mm, wire end sleeves
Suitable tools	Miniature screwdriver, size “00”	

Table 3-14 Power & logic supply connector X1/X2 – Specification and accessories

3.3.4.2 Motor & Hall Sensors (X3a/X4a) (X3b/X4b)

The controller is set to drive either maxon EC motor (BLDC, brushless DC motor) or maxon DC motor (brushed DC motor) with separated motor/encoder cable.

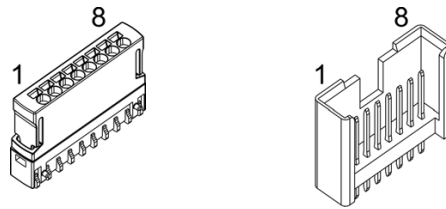


Figure 3-12 Motor & Hall sensors connectors X3a/X4a (left) and X3b/X4b (right)

X3a/X4a X3b/X4b Head A	Prefab Cable	Head B	Signal	Description
Pin	Color	Pin		
1			Motor (+M)	DC motor: Motor +
2			Motor (-M)	DC motor: Motor -
3			-	not connected
4			-	not connected
5			-	not connected
6			-	not connected
7			-	not connected
8			-	not connected

Table 3-15 Motor & Hall sensors connectors X3a/X4a / X3b/X4b – Pin assignment for maxon DC motor

X3a/X4a X3b/X4b Head A	Prefab Cable	Head B	Signal	Description
Pin	Color	Pin		
1			Motor winding 1	EC motor: Winding 1
2			Motor winding 2	EC motor: Winding 2
3			Motor winding 3	EC motor: Winding 3
4			V_{Sensor}	Sensor supply voltage (+5 VDC; $I_L \leq 100$ mA) External power supply for MR encoder
5			GND	Ground
6			Hall sensor 1	Hall sensor 1 input
7			Hall sensor 2	Hall sensor 2 input
8			Hall sensor 3	Hall sensor 3 input

Table 3-16 Motor & Hall sensors connectors X3a/X4a / X3b/X4b – Pin assignment for maxon EC motor

Motor & Hall Sensors Connector X3a/X4a (590737)		
Type	Spring-loaded contacts, 8 poles, pitch 2.54 mm	
Suitable plug	Harting har-flexicon 2.54 FPV-8 BK (14 31 081 3101 000) —included with every Compact version delivery—	
Suitable cables	Rigid	0.14...0.5 mm ² , AWG 26-20 / wire stripping length 6 mm
	Flexible	0.2...0.5 mm ² , AWG 24-20 / wire stripping length 6 mm 0.25...0.34 mm ² , AWG 24-22 / wire stripping length 6 mm, wire end sleeves
Suitable tools	Miniature screwdriver, size “00”	

Table 3-17 Motor & Hall sensors connector X3a/X4a – Specification and accessories

Motor & Hall Sensors Connector X3b/X4b	
Type	Mini module pin header, upright, single row, 8 poles, pitch 2.5 mm
Suitable plug	Lumberg crimping socket, 8 poles (3114 08)
Suitable contacts	Lumberg crimp contact for socket (3111 01) 0.10...0.25 mm ² AWG 27-23 Lumberg crimp contact for socket (3111 03) 0.30...0.60 mm ² AWG 22-19
Suitable tools	Lumberg hand crimper (CZ31)

Table 3-18 Motor & Hall sensors connector X3b/X4b – Specification and accessories

3.3.4.3 DC Motor (X3c)

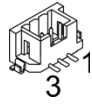


Figure 3-13 Motor connector X3c

X3c Head A Pin	Prefab Cable Color	Head B Pin	Signal	Description
1			Motor (+M)	DC motor: Motor +
2			Motor (-M)	DC motor: Motor -
3			-	not connected

Table 3-19 Motor connector X3c – Pin assignment

Specification / Accessories	
Type	Connector for discrete wire connection, pitch 2 mm
Suitable plug	Hirose crimping socket, 3 poles (DF3-3S-2C)
Suitable contacts	Hirose crimp contact for socket (DF3-22SC...)
Suitable tools	Hirose hand crimper (DF3-TA22HC)

Table 3-20 Motor connector X3c – Specification and accessories

3.3.4.4 Encoder (X5)



Connection of DC motor with integrated motor/encoder ribbon cable

If you are using a maxon DC motor with integrated motor/encoder ribbon cable, you will need to set the jumper JP1 accordingly in order to activate that option (→chapter “3.3.7 Jumper Configuration (JP1)” on page 3-42).

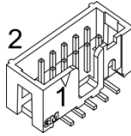


Figure 3-14 Encoder connector X5

X5 Head A Pin	Prefab Cable Color	Head B Pin	Signal	Description
1	brown	1	– Motor (+M)	not connected (factory setting) DC: Motor + (→note below)
2	white	2	V _{Sensor}	Sensor supply voltage (+5 VDC; I _L ≤100 mA)
3	red	3	GND	Ground
4	white	4	– Motor (–M)	not connected (factory setting) DC: Motor – (→note below)
5	orange	5	Channel A\	Channel A complement
6	white	6	Channel A	Channel A
7	yellow	7	Channel B\	Channel B complement
8	white	8	Channel B	Channel B
9	green	9	Channel I\	Channel I complement
10	white	10	Channel I	Channel I

Table 3-21 Encoder connector X5 – Pin assignment



Note

With the default factory setting, pins 1 (+M) and 4 (–M) are not connected.

In order to connect a DC motor as to the above table, you will need to change the factory setting and set the jumper JP1 to “ON” (→chapter “3.3.7 Jumper Configuration (JP1)” on page 3-42). To avoid any risk of damage, make sure that you use this setting option only for respective motors.

Accessories		
Suitable strain relief	Retainer	For sockets with strain relief: 1 retainer clip, height 13.5 mm, 3M (3505-8110)
		For sockets without strain relief: 1 retainer clip, height 7.9 mm, 3M (3505-8010)
	Latch	For sockets with strain relief: 2 pieces, 3M (3505-33B)

Table 3-22 Encoder connector X5 – Accessories

Continued on next page.


Encoder Cable (275934)	
	
Cross-section	10 x AWG28, round-jacket, twisted pair flat cable, pitch 1.27 mm, grey
Length	3.2 m
Head A	DIN 41651 female, pitch 2.54 mm, 10 poles, with strain relief
Head B	DIN 41651 plug, pitch 2.54 mm, 10 poles, with strain relief

Table 3-23 Encoder Cable

Setup
Pin Assignment for Connector Boards & Compact Versions

3.3.4.5 Sensor (X6)

Additional sensors, both incremental and serial encoders, can be connected.

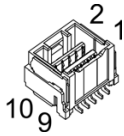


Figure 3-15 Sensor connector X6

X6 Head A Pin	Prefab Cable Color	Head B Pin	Signal	Description
1	white	1	Channel A HsDigIN1	Digital/analog incremental encoder channel A High-speed digital input 1
2	brown	2	Channel A\ HsDigIN1\ 	Digital/analog incremental encoder channel A complement High-speed digital input 1 complement
3	green	3	Channel B HsDigIN2	Digital/analog incremental encoder channel B High-speed digital input 2
4	yellow	4	Channel B\ HsDigIN2\ 	Digital/analog incremental encoder channel B complement High-speed digital input 2 complement
5	grey	5	Channel I HsDigIN3 Clock HsDigOUT1	Digital/analog incremental encoder channel I High-speed digital input 3 Clock (SSI) High-speed digital output 1
6	pink	6	Channel I\ HsDigIN3\ Clock\ HsDigOUT1\ 	Digital/analog incremental encoder channel I complement High-speed digital input 3 complement Clock (SSI) complement High-speed digital output 1 complement
7	blue	7	Data HsDigIN4	Data (SSI) High-speed digital input 4
8	red	8	Data\ HsDigIN4\ 	Data (SSI) complement High-speed digital input 4 complement
9	black	9	GND	Ground
10	violet	10	V _{Aux}	Auxiliary output voltage (+5 VDC; I _L ≤150 mA)

Table 3-24 Sensor connector X6 – Pin assignment

Continued on next page.

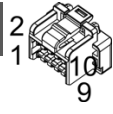
Sensor Cable 5x2core (520852)		
<div style="display: flex; justify-content: space-between; align-items: center;"> <div style="text-align: center;"> A  </div> <div style="text-align: center;"> B </div> </div>		
Cross-section	5 x 2 x 0.14 mm ² , twisted pair, grey	
Length	3 m	
Head A	Plug	Molex CLIK-Mate, dual row, 10 poles (503149-1000)
	Contacts	Molex CLIK-Mate crimp terminals (502579)
Head B	Wire end sleeves 0.14 mm ²	

Table 3-25 Sensor Cable 5x2core

Setup
Pin Assignment for Connector Boards & Compact Versions

3.3.4.6 Digital I/O (X7)

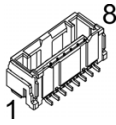


Figure 3-16 Digital I/O connector X7

X7 Head A Pin	Prefab Cable Color	Head B Pin	Signal	Description
1	white	1	DigIN1	Digital input 1
2	brown	2	DigIN2	Digital input 2
3	green	3	DigIN3	Digital input 3
4	yellow	4	DigIN4	Digital input 4
5	grey	5	DigOUT1	Digital output 1
6	pink	6	DigOUT2	Digital output 2
7	blue	7	GND	Ground
8	red	8	V _{Aux}	Auxiliary output voltage (+5 VDC; I _L ≤150 mA)

Table 3-26 Digital I/O connector X7 – Pin assignment

Signal Cable 8core (520853)		
A	 8 1	B
Cross-section	8 x 0.14 mm ² , grey	
Length	3 m	
Head A	Plug	Molex CLIK-Mate, single row, 8 poles (502578-0800)
	Contacts	Molex CLIK-Mate crimp terminals (502579)
Head B	Wire end sleeves 0.14 mm ²	

Table 3-27 Signal Cable 8core

3.3.4.7 Analog I/O (X8)

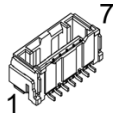


Figure 3-17 Analog I/O connector X8

X8 Head A Pin	Prefab Cable Color	Head B Pin	Signal	Description
1	white	1	AnIN1+	Analog input 1, positive signal
2	brown	2	AnIN1-	Analog input 1, negative signal
3	green	3	AnIN2+	Analog input 2, positive signal
4	yellow	4	AnIN2-	Analog input 2, negative signal
5	grey	5	AnOUT1	Analog output 1
6	pink	6	AnOUT2	Analog output 2
7	blue	7	GND	Ground

Table 3-28 Analog I/O connector X8 – Pin assignment

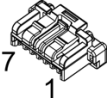
Signal Cable 7core (520854)		
A		B
Cross-section	7 x 0.14 mm ² , grey	
Length	3 m	
Head A	Plug	Molex CLIK-Mate, single row, 7 poles (502578-0700)
	Contacts	Molex CLIK-Mate crimp terminals (502579)
Head B	Wire end sleeves 0.14 mm ²	

Table 3-29 Signal Cable 7core

3.3.4.8 STO (X9)

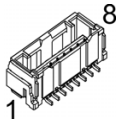


Figure 3-18 STO connector X9



Activation of power stage

In order to activate the power stage, either **both** STO inputs must be powered or the «STO Idle Connector» (→ Table 3-31; included with every Compact version delivery) must be plugged.

X9 Head A Pin	Prefab Cable Color	Head B Pin	Signal	Description
1	white	1	STO-IN1+	Safe Torque Off input 1, positive signal
2	brown	2	STO-IN1-	Safe Torque Off input 1, negative signal
3	green	3	STO-IN2+	Safe Torque Off input 2, positive signal
4	yellow	4	STO-IN2-	Safe Torque Off input 2, negative signal
5	grey	5	STO-OUT+	Safe Torque Off output, positive signal
6	pink	6	STO-OUT-	Safe Torque Off output, negative signal
7	blue	7	GND	Ground
8	red	8	V _{STO}	Activation voltage for STO inputs (+5 VDC) Note: Do not use this voltage for any other purpose

Table 3-30 STO connector X9 – Pin assignment

For the matching prefab cable assembly → Table 3-27 on page 3-32.

STO Idle Connector (520860) —included with every Compact version delivery—	
Plug	Molex CLIK-Mate, single row, 8 poles (502578-0800) with cable bridges

Table 3-31 STO Idle Connector

3.3.4.9 RS232 (X10)

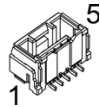


Figure 3-19 RS232 connector X10

X10 Head A Pin	Prefab Cable Color	Head B Pin	Signal	Description
1	white	3	EPOS_RxD	EPOS RS232 receive
2	brown	5	GND	Ground
3	green	2	EPOS_TxD	EPOS RS232 transmit
4	yellow	5	GND	Ground
5	Shield	Housing	Shield	Cable shield

Table 3-32 RS232 connector X10 – Pin assignment

RS232-COM Cable (520856)		
Cross-section	2 x 2 x 0.14 mm ² , twisted pair, shielded	
Length	3 m	
Head A	Plug	Molex CLIK-Mate, single row, 5 poles (502578-0500)
	Contacts	Molex CLIK-Mate crimp terminals (502579)
Head B	Female D-Sub connector DIN 41652, 9 poles, with mounting screws	

Table 3-33 RS232-COM Cable

Setup
Pin Assignment for Connector Boards & Compact Versions

3.3.4.10 CAN 1 (X11) CAN 2 (X12)

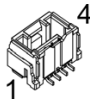


Figure 3-20 CAN 1 connector X11 and CAN 2 connector X12

X11/X12 Head A Pin	Prefab Cable Color	Head B Pin	Signal	Description
1	white	7	CAN high	CAN high bus line
2	brown	2	CAN low	CAN low bus line
3	green	3	GND	Ground
4	Shield	5	Shield	Cable shield

Table 3-34 CAN 1 connector X11/CAN 2 connector X12 – Pin assignment

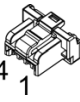
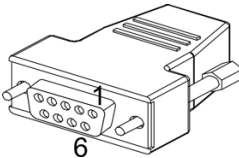
CAN-COM Cable (520857)		
A 	 B	
Cross-section	2 x 2 x 0.14 mm ² , twisted pair, shielded	
Length	3 m	
Head A	Plug	Molex CLIK-Mate, single row, 4 poles (502578-0400)
	Contacts	Molex CLIK-Mate crimp terminals (502579)
Head B	Female D-Sub connector DIN 41652, 9 poles, with mounting screws	

Table 3-35 CAN-COM Cable

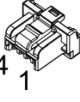
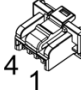
CAN-CAN Cable (520858)		
A 	 B	
Cross-section	2 x 2 x 0.14 mm ² , twisted pair, shielded	
Length	3 m	
Head A	Plug	Molex CLIK-Mate, single row, 4 poles (502578-0400)
	Contacts	Molex CLIK-Mate crimp terminals (502579)
Head B	Plug	Molex CLIK-Mate, single row, 4 poles (502578-0400)
	Contacts	Molex CLIK-Mate crimp terminals (502579)

Table 3-36 CAN-CAN Cable

3.3.5 Adapters for maxon EC motors with Flexprint Cable (FPC)

Use the ready-made adapters for easy connection of maxon EC motors with built-in FPC (Flexprint cable). The adapters are color-coded and match the following motors:

Adapter				Suitable motors with Hall sensors (not concluding)	
Order number	Designation	Color	Poles	Type	Rating [W]
418719	Adapter BLACK FPC11poles	black	11	EC 10 EC 13 EC 20 flat EC 32 flat EC 45 flat	8 6 / 12 3 / 5 6 / 15 12 / 30
418723	Adapter BLUE FPC8poles	blue	8	EC 6 EC 8 EC 9.2 flat	1.5 / 2 2 0.5
418721	Adapter GREEN FPC8poles	green	8	EC 6 EC 10 flat	1.2 0.2

Table 3-37 Adapters for Flexprint cables

ADAPTER BLACK FPC11POLES

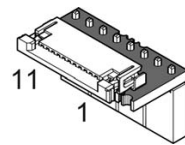


Figure 3-21 Adapter BLACK FPC11poles

Adapter BLACK Pin	Signal	Description
1	V_{Sensor}	Sensor supply voltage (+5 VDC; $I_L \leq 100$ mA)
2	Hall sensor 3	Hall sensor 3 input
3	Hall sensor 1	Hall sensor 1 input
4	Hall sensor 2	Hall sensor 2 input
5	GND	Ground
6	Motor winding 3	EC motor: Winding 3
7	Motor winding 3	EC motor: Winding 3
8	Motor winding 2	EC motor: Winding 2
9	Motor winding 2	EC motor: Winding 2
10	Motor winding 1	EC motor: Winding 1
11	Motor winding 1	EC motor: Winding 1

Table 3-38 Adapter BLACK FPC11poles – Pin assignment

ADAPTER BLUE FPC8POLES

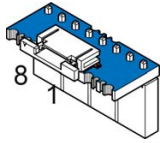


Figure 3-22 Adapter BLUE FPC8poles

Adapter BLUE Pin	Signal	Description
1	Motor winding 1	EC motor: Winding 1
2	Motor winding 2	EC motor: Winding 2
3	Motor winding 3	EC motor: Winding 3
4	V_{Sensor}	Sensor supply voltage (+5 VDC; $I_L \leq 100 \text{ mA}$)
5	GND	Ground
6	Hall sensor 1	Hall sensor 1 input
7	Hall sensor 2	Hall sensor 2 input
8	Hall sensor 3	Hall sensor 3 input

Table 3-39 Adapter BLUE FPC8poles – Pin assignment

ADAPTER GREEN FPC8POLES

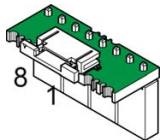
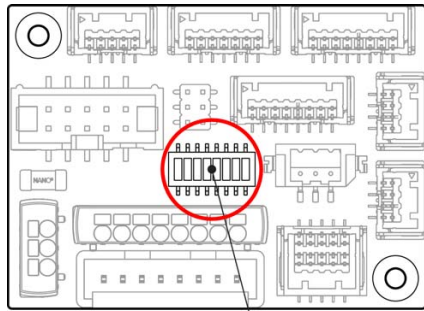


Figure 3-23 Adapter GREEN FPC8poles

Adapter GREEN Pin	Signal	Description
1	Motor winding 3	EC motor: Winding 3
2	Motor winding 2	EC motor: Winding 2
3	Hall sensor 3	Hall sensor 3 input
4	V_{Sensor}	Sensor supply voltage (+5 VDC; $I_L \leq 100 \text{ mA}$)
5	GND	Ground
6	Hall sensor 1	Hall sensor 1 input
7	Hall sensor 2	Hall sensor 2 input
8	Motor winding 1	EC motor: Winding 1

Table 3-40 Adapter GREEN FPC8poles – Pin assignment

3.3.6 DIP Switch Configuration (SW1)



SW1

Figure 3-24 EPOS4 CB 24/1.5 CAN – DIP switch SW1

3.3.6.1 CAN ID (Node Address)

The CAN ID is set with DIP switches 1...5. The node address (1...31) may be coded using binary code.



Setting the CAN ID by DIP switch SW1

- By setting the DIP switch (1...5) address 0 (“OFF”), the CAN ID may be set by software (changing object “Node ID”, range 1...127).
- The CAN ID results in the summed values of DIP switch addresses 1 (“ON”).
- DIP switches 6...8 do not have any impact on the CAN ID.

Switch	Binary Code	Valence	Setting
1	2^0	1	
2	2^1	2	
3	2^2	4	
4	2^3	8	
5	2^4	16	

Table 3-41 DIP switch SW1 – Binary code values

Continued on next page.

Setup
Pin Assignment for Connector Boards & Compact Versions

The set CAN ID (node address) can be observed by adding the valence of all activated switches. Use the following table as a (non-concluding) guide:

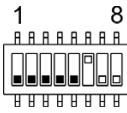
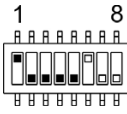
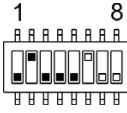
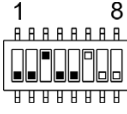
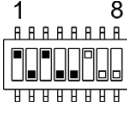
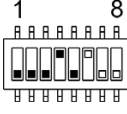
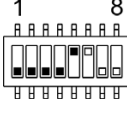
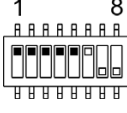
Setting	Switch					Node Address
	1	2	3	4	5	
 ON OFF	0	0	0	0	0	–
 ON OFF	1	0	0	0	0	1
 ON OFF	0	1	0	0	0	2
 ON OFF	0	0	1	0	0	4
 ON OFF	1	0	1	0	0	5
 ON OFF	0	0	0	1	0	8
 ON OFF	0	0	0	0	1	16
 ON OFF	1	1	1	1	1	31
0 = Switch "OFF" 1 = Switch "ON"						

Table 3-42 DIP switch SW1 – Examples

3.3.6.2 CAN automatic Bit Rate Detection

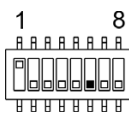
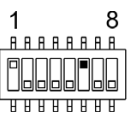
Switch	OFF	ON
6	 ON OFF Automatic bit rate detection deactivated	 ON OFF Automatic bit rate detection activated (factory setting)

Table 3-43 DIP switch SW1 – CAN automatic bit rate detection

3.3.6.3 CAN Bus Termination

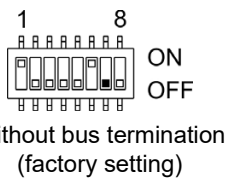
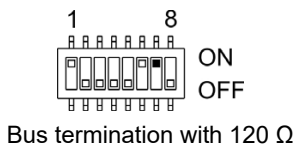
Switch	OFF	ON
7	 <p>Without bus termination (factory setting)</p>	 <p>Bus termination with 120 Ω</p>

Table 3-44 DIP switch SW1 – CAN bus termination

3.3.6.4 Digital Input Level

For details → chapter “3.4.7 Digital I/Os” on page 3-60.

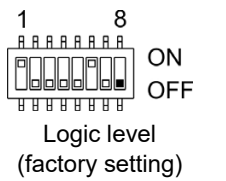
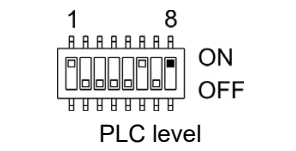
Switch	OFF	ON
8	 <p>Logic level (factory setting)</p>	 <p>PLC level</p>

Table 3-45 DIP switch SW1 – Digital input level

3.3.7 Jumper Configuration (JP1)

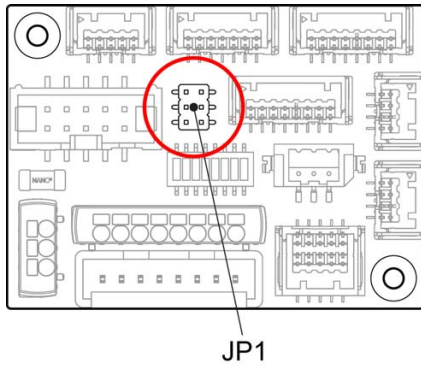


Figure 3-25 EPOS4 CB 24/1.5 CAN – Jumper JP1

3.3.7.1 Connection of DC Motor with integrated Motor/Encoder Ribbon Cable

The motor windings of a DC motor with MR encoder are connected via an integrated motor/encoder ribbon cable. To activate that option, you will need to set the jumper JP1 accordingly.



Settings for jumper JP1

- Bridging the jumper pins 1/2 and 5/6 disconnects the motor windings from the encoder connector X5 (→Table 3-46; “OFF”)
- Bridging the jumper pins 2/4 and 3/5 connects the motor windings (+M) and (–M) to the encoder connector X5, pins 1 and 4 (→Table 3-46; “ON”)

JP1	OFF	ON
Bridges	<p>Motor windings disconnected (factory setting)</p>	<p>Motor windings connected</p>

Table 3-46 Jumper JP1 – Power supply for DC motor winding

3.3.8 Spare Parts

Order number	Description
520860	STO Idle Connector X9
590736	Power & Logic Supply Connector X1/X2
590737	Motor & Hall Sensors Connector X3a/X4a

Table 3-47 Spare parts list

3.4 Connection Specifications

The actual connection will depend on the overall configuration of your drive system and the type of motor you will be using. Follow the description in given order and choose the wiring diagram (→ as of page 5-83) that best suits the components you are using.



How to read the following data

The following tables feature, where applicable, connection details for both versions the Module and the Compact. Thereby,...

- the column «Module Header Pin» refers to the header's pin number.
Example: **A23...A29** means header A, pins 23 thru 29
- the column «Compact/CB Connector Pin» refers to the connector's pin number.
Example: **X1/X2 | 2** means connector X1/X2, pin 2

For easier legibility, the subsequently used circuit diagrams refer to the Module. For the corresponding Compact's circuitry take the second column «Compact/CB Connector Pin» into account.

3.4.1 Power Supply

Basically, any power supply may be used provided that it meets the below stated minimum requirements.

Module Header Pin	Compact/CB Connector Pin	Signal	Description
A23...A29**	X1/X2 2	+V _{CC}	Power supply voltage (+10...+24 VDC)
A30...A36**	X1/X2 1	GND	Ground
** Connect all pins in respect to the individual pin current rating.			

Table 3-48 Power supply – Pin assignment

Power supply requirements	
Output voltage	+V _{CC} 10...24 VDC
Absolute output voltage	min. 8 VDC; max. 28 VDC
Output current	Depending on load <ul style="list-style-type: none"> • continuous max. 1.5 A • short-time (acceleration, <30 s) max. 4.5 A

- 1) Use the formula below to calculate the required voltage under load.
- 2) Choose a power supply according to the calculated voltage. Thereby consider:
 - a) During braking of the load, the power supply must be capable of buffering the recovered kinetic energy (for example, in a capacitor).
 - b) If you are using an electronically stabilized power supply, make sure that the overcurrent protection circuit is configured inoperative within the operating range.

Continued on next page.



The formula already takes the following into account:

- Maximum PWM duty cycle of 90%
- Controller's max. voltage drop of 1 V @ 1.5 A

KNOWN VALUES:

- Operating torque M [mNm]
- Operating speed n [rpm]
- Nominal motor voltage U_N [Volt]
- Motor no-load speed at U_N ; n_0 [rpm]
- Speed/torque gradient of the motor $\Delta n/\Delta M$ [rpm/mNm]

SOUGHT VALUE:

- Supply voltage $+V_{CC}$ [Volt]

SOLUTION:

$$V_{CC} \geq \left[\frac{U_N}{n_0} \cdot \left(n + \frac{\Delta n}{\Delta M} \cdot M \right) \cdot \frac{1}{0.9} \right] + 1 [V]$$

3.4.2 Logic Supply



Separate power supply

The logic part of the controller may be supplied by separate supply voltage provided that it meets the below stated minimum requirements.

- *Module:* The logic supply must be connected separately.
- *Compact:* If not supplied separately, the logic supply is internally connected to the power supply.

Module Header Pin	Compact/CB Connector Pin	Signal	Description
A22	X1/X2 3	$+V_c$	Logic supply voltage (+10...+24 VDC)
A30...A36**	X1/X2 1	GND	Ground
** Connect all pins in respect to the individual pin current rating.			

Table 3-49 Logic supply – Pin assignment

Power supply requirements	
Output voltage	$+V_c$ 10...24 VDC
Absolute supply voltage	min. 8 VDC; max. 28 VDC
Min. output power	P_c min. 3.5 W

3.4.3 Motor

The EPOS4 is set to drive either maxon DC motors (brushed) or maxon EC motors (brushless).

Module Header Pin	Compact/CB Connector Pin	Signal	Description
A1...A7**	X3a/X4a 1 X3b/X4b 1 X3c 1	Motor (+M)	Motor +
A8...A14**	X3a/X4a 2 X3b/X4b 2 X3c 2	Motor (-M)	Motor -
-	X3a/X4a 3 X3b/X4b 3 X3c 3	-	not connected
** Connect all pins in respect to the individual pin current rating.			

Table 3-50 DC motor – Pin assignment

Module Header Pin	Compact/CB Connector Pin	Signal	Description
A1...A7**	X3a/X4a 1 X3b/X4b 1	Motor winding 1	Winding 1
A8...A14**	X3a/X4a 2 X3b/X4b 2	Motor winding 2	Winding 2
A15...A21**	X3a/X4a 3 X3b/X4b 3	Motor winding 3	Winding 3
** Connect all pins in respect to the individual pin current rating.			

Table 3-51 EC motor – Pin assignment

3.4.4 Hall Sensor

Module Header Pin	Compact/CB Connector Pin	Signal	Description
A30...A36	X3a/X4a 5 X3b/X4b 5	GND	Ground
A37	X3a/X4a 6 X3b/X4b 6	Hall sensor 1	Hall sensor 1 input
A38	X3a/X4a 7 X3b/X4b 7	Hall sensor 2	Hall sensor 2 input
A39	X3a/X4a 8 X3b/X4b 8	Hall sensor 3	Hall sensor 3 input
A40	X3a/X4a 4 X3b/X4b 4	V_{Sensor}	Sensor supply voltage (+5 VDC; $I_L \leq 100 \text{ mA}$)

Table 3-52 Hall sensor – Pin assignment

Hall sensor	
Sensor supply voltage (V_{Sensor})	+5 VDC
Max. Hall sensor supply current	30 mA
Input voltage	0...24 VDC
Max. input voltage	+24 VDC
Logic 0	typically <0.8 V
Logic 1	typically >2.0 V
Internal pull-up resistor	10 k Ω (referenced to +5.45 V)

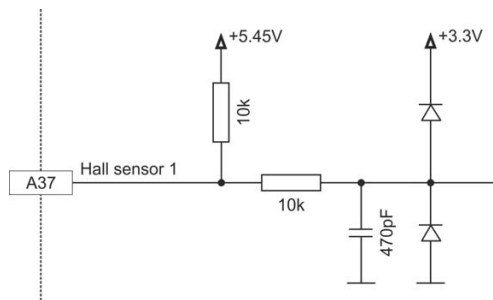


Figure 3-26 Hall sensor 1 input circuit (analogously valid for Hall sensors 2 & 3)

3.4.5 Encoder

**Best practice**

- Differential signals offer good resistance against electrical interference. Therefore, **we recommend using a differential scheme**. Nevertheless, the controller supports both schemes – differential and single-ended (unsymmetrical).
- For best performance, **we strongly recommend using encoders with a line driver**. Otherwise, limitations may apply due to slow switching edges.
- Even though 2-channel will do, **we strongly recommend to use only 3-channel versions**.

Module Header Pin	Compact/CB Connector Pin	Signal	Description
A30...A36	X5 3	GND	Ground
A40	X5 2	V_{Sensor}	Sensor supply voltage (+5 VDC; $I_L \leq 100$ mA)
A41	X5 6	Channel A	Digital incremental encoder channel A
A42	X5 5	Channel A \bar{A}	Digital incremental encoder channel A complement
A43	X5 8	Channel B	Digital incremental encoder channel B
A44	X5 7	Channel B \bar{B}	Digital incremental encoder channel B complement
A45	X5 10	Channel I	Digital incremental encoder channel I
A46	X5 9	Channel I \bar{I}	Digital incremental encoder channel I complement

Table 3-53 Encoder – Pin assignment

Encoder (differential)	
Sensor supply voltage (V_{Sensor})	+5 VDC
Max. encoder supply current	70 mA
Min. differential input voltage	± 200 mV
Max. input voltage	± 12 VDC
Line receiver (internal)	EIA RS422 standard
Max. input frequency	6.25 MHz

Continued on next page.

Setup Connection Specifications

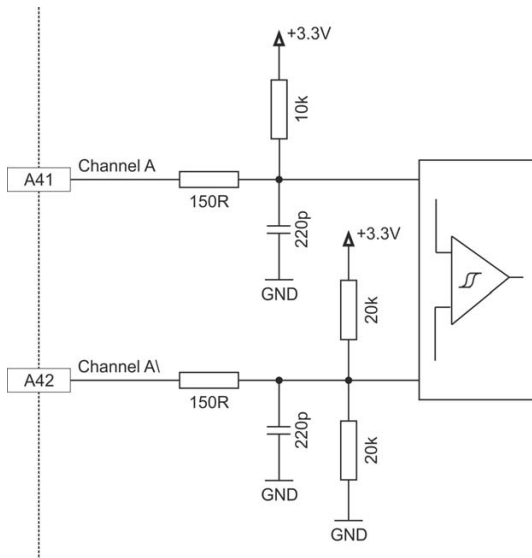


Figure 3-27 Encoder input circuit Ch A “differential” (analogously valid for Ch B & Ch I)

Encoder (single-ended)		
Sensor supply voltage (V_{Sensor})	+5 VDC	
Max. encoder supply current	70 mA	
Input voltage	0...5 VDC	
Max. input voltage	± 12 VDC	
Logic 0	<1.0 V	
Logic 1	>2.4 V	
Input high current	I_{IH} = typically +250 μA @ 5 V	
Input low current	I_{IL} = typically -330 μA @ 0 V	
Max. input frequency	Push-pull	Open collector
	6.25 MHz	40 kHz (internal pull-up only)
		150 kHz (additional external 3k3 pull-up)

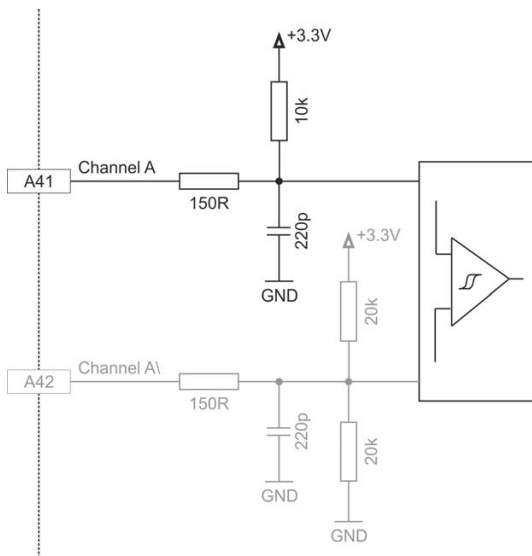


Figure 3-28 Encoder input circuit Ch A “single-ended” (analogously valid for Ch B & Ch I)

3.4.6 Sensor



Check on the applied sensor's data sheet

If the specified inrush current or the maximum continuous current of the sensor should exceed 150 mA, you can connect the sensor supply voltage (V_{Sensor}) in parallel to the auxiliary output voltage (V_{Aux}).

3.4.6.1 Incremental Encoder

Module Header Pin	Compact/CB Connector Pin	Signal	Description
B7	X6 1	Channel A	Digital/analog incremental encoder channel A
B8	X6 2	Channel A\	Digital/analog incremental encoder channel A complement
B9	X6 3	Channel B	Digital/analog incremental encoder channel B
B10	X6 4	Channel B\	Digital/analog incremental encoder channel B complement
B11	X6 5	Channel I	Digital/analog incremental encoder channel I
B12	X6 6	Channel I\	Digital/analog incremental encoder channel I complement
B15	X6 10	V_{Aux}	Auxiliary output voltage (+5 VDC; $I_L \leq 150$ mA)
B16	X6 9	GND	Ground

Table 3-54 Incremental encoder – Pin assignment

Digital incremental encoder (differential)	
Auxiliary output voltage (V_{Aux})	+5 VDC
Max. auxiliary supply current	150 mA
Min. differential input voltage	± 200 mV
Max. input voltage	+12 VDC
Line receiver (internal)	EIA RS422 standard
Max. input frequency	6.25 MHz

Continued on next page.

Setup
Connection Specifications

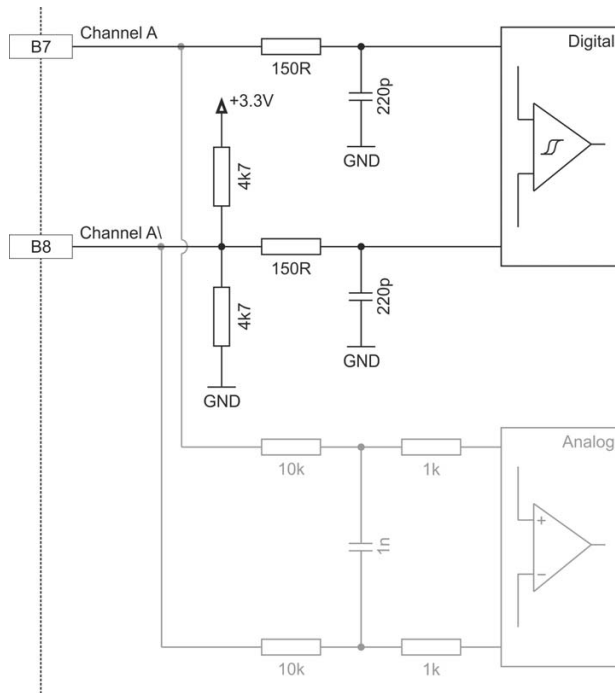


Figure 3-29 Digital incremental encoder input circuit Ch A “differential” (analogously valid for Ch B)

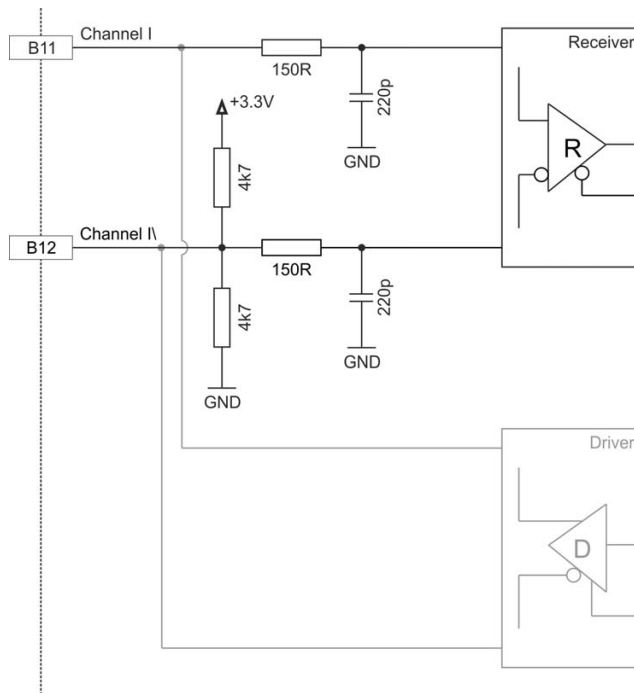


Figure 3-30 Digital incremental encoder input circuit Ch I

Digital incremental encoder (single-ended)		
Auxiliary output voltage (V_{Aux})	+5 VDC	
Max. auxiliary supply current	150 mA	
Input voltage	0...5 VDC	
Max. input voltage	± 12 VDC	
Logic 0	< 1.0 V	
Logic 1	> 2.4 V	
Input high current	typically $210 \mu\text{A}$ @ +5 VDC (channel A, B) typically $60 \mu\text{A}$ @ +5 VDC (channel I)	
Input low current	typically $-80 \mu\text{A}$ @ 0 VDC (channel A, B) typically $-7 \mu\text{A}$ @ 0 VDC (channel I)	
Max. input frequency	Push-pull 6.25 MHz	Open collector 100 kHz (additional external 3k3 pull-up)

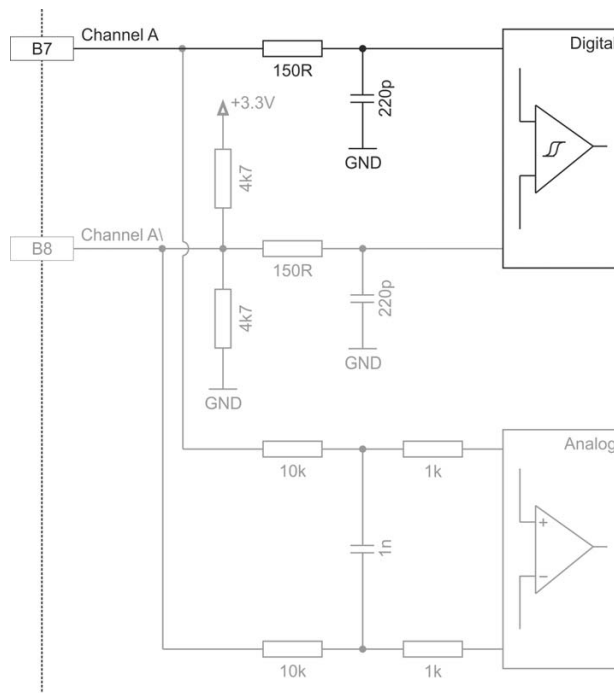


Figure 3-31 Digital incremental encoder input circuit Ch A “single-ended” (analogously valid for Ch B)

Continued on next page.

Setup Connection Specifications

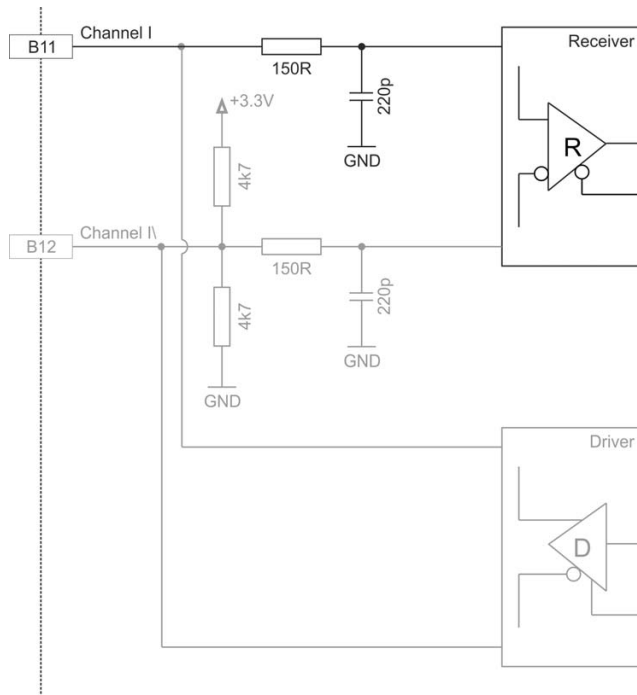


Figure 3-32 Digital incremental encoder input circuit Ch I

Analog incremental encoder (differential)	
Auxiliary output voltage (V_{Aux})	+5 VDC
Max. auxiliary supply current	150 mA
Input voltage	± 1.8 V (differential)
Max. input voltage	± 12 VDC
Common mode voltage	-9...+4 VDC (referenced to GND)
Input resistance	typically 10 k Ω
A/D converter	12-bit
Resolution	0.88 mV
Bandwidth	10 kHz

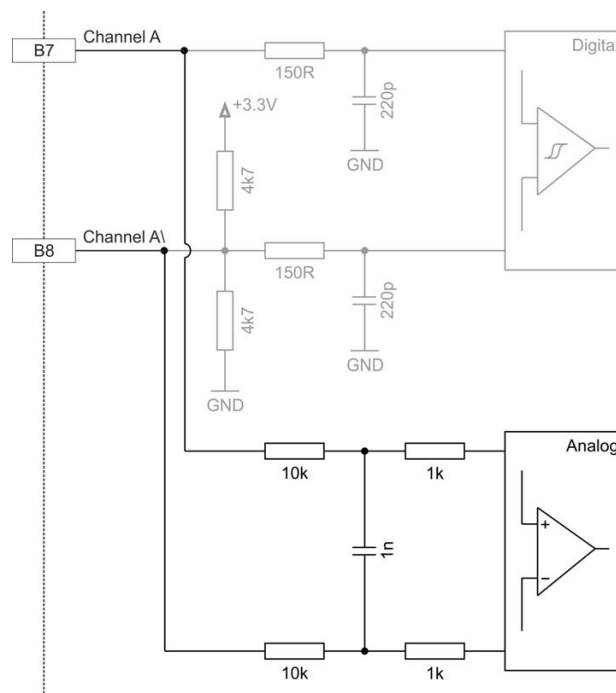


Figure 3-33 Analog incremental encoder input circuit Ch A “differential” (analogously valid for Ch B)

Continued on next page.

Setup Connection Specifications

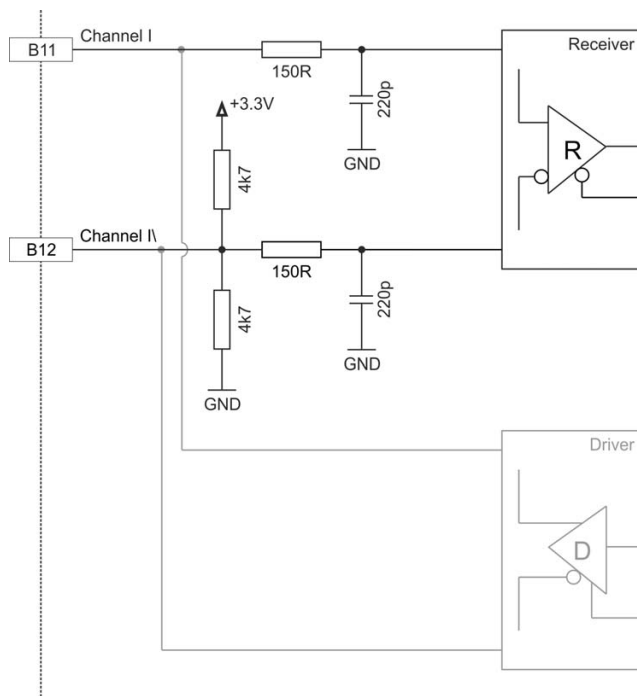


Figure 3-34 Analog incremental encoder input circuit Ch I (digital evaluation)

3.4.6.2 SSI Absolute Encoder

Module Header Pin	Compact/CB Connector Pin	Signal	Description
B11	X6 5	Clock	Clock (SSI)
B12	X6 6	Clock\	Clock (SSI) complement
B13	X6 7	Data	Data (SSI)
B14	X6 8	Data\	Data (SSI) complement
B15	X6 10	V _{Aux}	Auxiliary output voltage (+5 VDC; I _L ≤150 mA)
B16	X6 9	GND	Ground

Table 3-55 SSI absolute encoder – Pin assignment

SSI absolute encoder	
Auxiliary output voltage (V _{Aux})	+5 VDC
Max. auxiliary supply current	150 mA
Min. differential input voltage	±200 mV
Min. differential output voltage	±1.8 V @ external load R=54 Ω
Max. output current	40 mA
Line receiver (internal)	EIA RS422 standard
Max. encoder input/output frequency	5 MHz

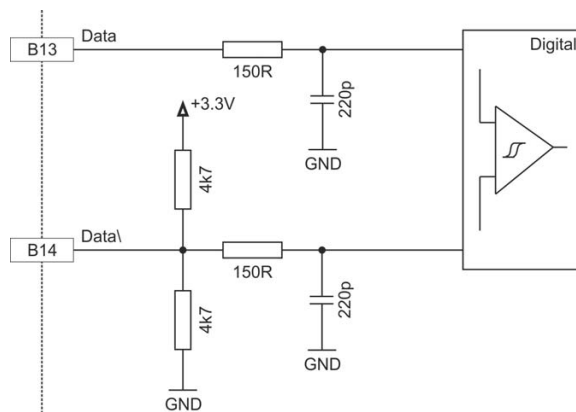


Figure 3-35 SSI absolute encoder data input

Continued on next page.

Setup Connection Specifications

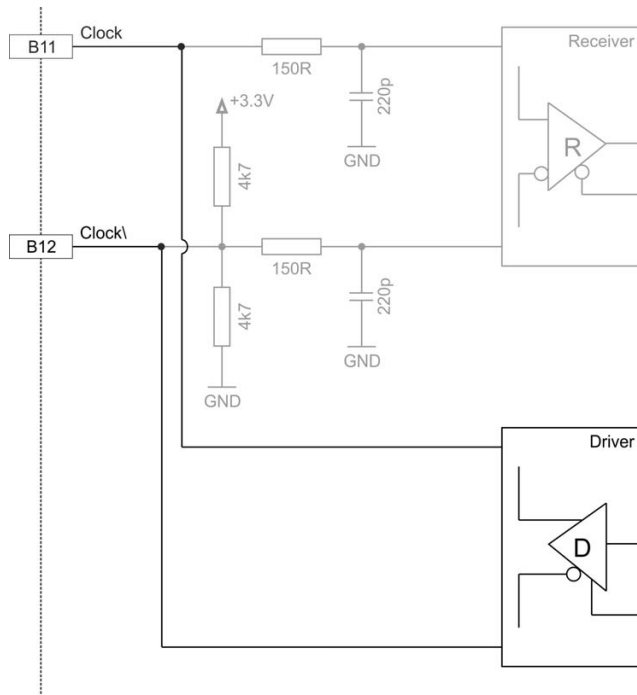


Figure 3-36 SSI absolute encoder clock output

3.4.6.3 High-speed Digital I/Os

Alternatively, the sensor interface can be used for high-speed digital I/O operation.

Module Header Pin	Compact/CB Connector Pin	Signal	Description
B7	X6 1	HsDigIN1	High-speed digital input 1
B8	X6 2	HsDigIN1\	High-speed digital input 1 complement
B9	X6 3	HsDigIN2	High-speed digital input 2
B10	X6 4	HsDigIN2\	High-speed digital input 2 complement
B11	X6 5	HsDigIN3 HsDigOUT1	High-speed digital input 3 High-speed digital output 1
B12	X6 6	HsDigIN3\ HsDigOUT1\	High-speed digital input 3 complement High-speed digital output 1 complement
B13	X6 7	HsDigIN4	High-speed digital input 4
B14	X6 8	HsDigIN4\	High-speed digital input 4 complement
B15	X6 10	V _{Aux}	Auxiliary output voltage (+5 VDC; I _L ≤150 mA)
B16	X6 9	GND	Ground

Table 3-56 High-speed digital I/Os – Pin assignment

High-speed digital input 1...4 (differential)	
Max. input voltage	±12 VDC
Min. differential input voltage	±200 mV
Line receiver (internal)	EIA RS422 standard
Max. input frequency	6.25 MHz

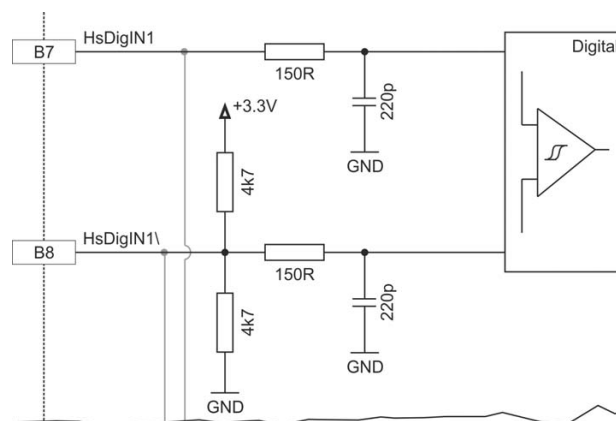


Figure 3-37 HsDigIN1 circuit “differential” (analogously valid for HsDigIN2...4)

High-speed digital input 1...4 (single-ended)	
Input voltage	0...5 VDC
Max. input voltage	±12 VDC
Logic 0	<1.0 V
Logic 1	>2.4 V
Input high current	typically 210 μ A @ +5 VDC (HsDigIN1, 2) typically 60 μ A @ +5 VDC (HsDigIN3, 4)
Input low current	typically -80 μ A @ 0 VDC (HsDigIN1, 2) typically -7 μ A @ 0 VDC (HsDigIN3, 4)
Max. input frequency	6.25 MHz

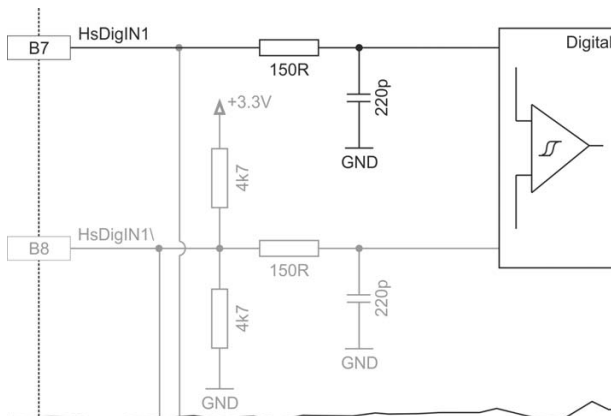


Figure 3-38 HsDigIN1 circuit “single-ended” (analogously valid for HsDigIN2...4)

High-speed digital output 1	
Min. differential output voltage	$\pm 1.8 \text{ V @ external load } R=54 \Omega$
Max. output current	40 mA
Line transceiver (internal)	EIA RS422 standard
Max. output frequency	6.25 MHz

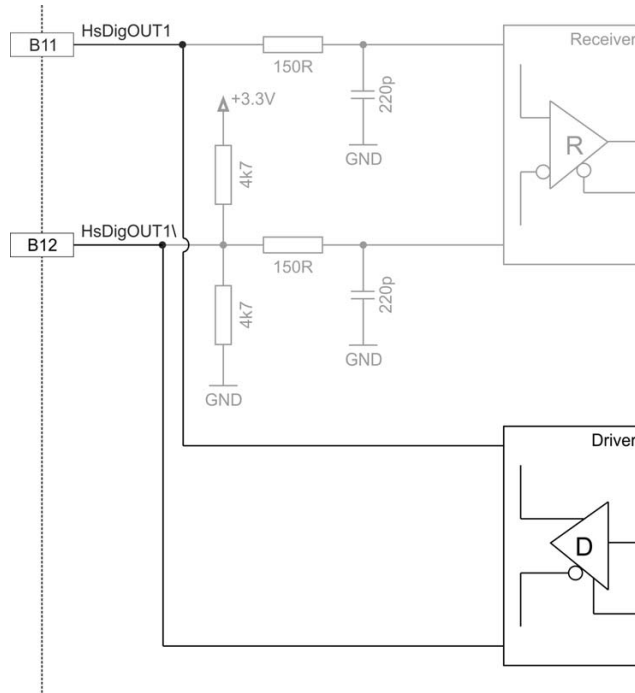


Figure 3-39 HsDigOUT1 output circuit

3.4.7 Digital I/Os

3.4.7.1 Module

Module Header Pin	Signal	Description
B1	DigIN1	Digital input 1
B2	DigIN2	Digital input 2
B3	DigIN3	Digital input 3
B4	DigIN4	Digital input 4
B5	DigOUT1	Digital output 1
B6	DigOUT2	Digital output 2
B15	V _{Aux}	Auxiliary output voltage (+5 VDC; I _L ≤ 150 mA)
B16	GND	Ground

Table 3-57 Digital I/Os – Pin assignment – Module

Digital inputs 1...4 (Module)	
Input voltage	0...36 VDC
Max. input voltage	±36 VDC
Logic 0	<0.8 V
Logic 1	>2.1 V
Input resistance	typically 47 kΩ (<3.3 V) typically 37.5 kΩ (@ 5 V) typically 25.5 kΩ (@ 24 V)
Input current at logic 1	typically 135 μA @ +5 VDC
Switching delay	<300 μs

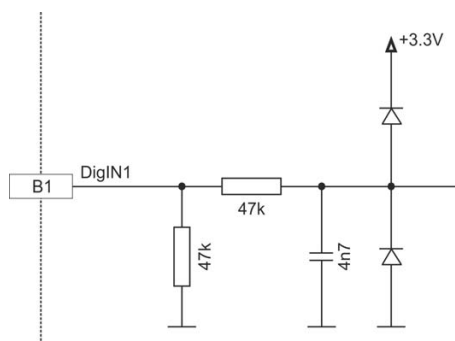


Figure 3-40 DigIN1 circuit (analogously valid for DigIN2...4) – Module

3.4.7.2 Compact

Compact/CB Connector Pin	Signal	Description
X7 1	DigIN1	Digital input 1
X7 2	DigIN2	Digital input 2
X7 3	DigIN3	Digital input 3
X7 4	DigIN4	Digital input 4
X7 5	DigOUT1	Digital output 1
X7 6	DigOUT2	Digital output 2
X7 7	GND	Ground
X7 8	V _{Aux}	Auxiliary output voltage (+5 VDC; I _L ≤150 mA)

Table 3-58 Digital I/Os – Pin assignment – Compact

Digital inputs 1...4 (Compact / Logic level setting)	
Input voltage	0...30 VDC
Max. input voltage	±30 VDC
Logic 0	<0.8 V
Logic 1	>2.0 V
Input current at logic 1	250 µA @ 5 VDC
Switching delay	<300 µs @ 5 VDC

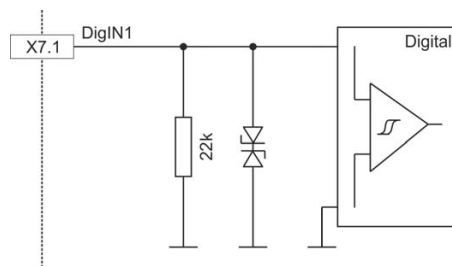


Figure 3-41 DigIN1 circuit (analogously valid for DigIN2...4) – Compact / Logic level setting

Continued on next page.

Digital inputs 1...4 (Compact / PLC level setting)	
Input voltage	0...30 VDC
Max. input voltage	±30 VDC
Logic 0	<5.5 V
Logic 1	>9 V
Input current at logic 1	>2 mA @ 9 VDC typically 3.5 mA @ 24 VDC
Switching delay	<300 μs @ 24 VDC

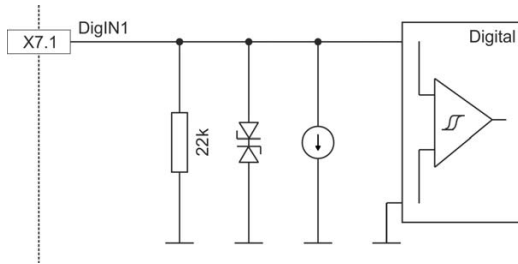


Figure 3-42 DigIN1 circuit (analogously valid for DigIN2...4) – Compact / PLC level setting

For pin assignment of digital outputs → Table 3-57 and Table 3-58.

Digital outputs 1...2	
Circuit	Open drain (internal pull-up resistor 2k2 and diode to +5.45 VDC)

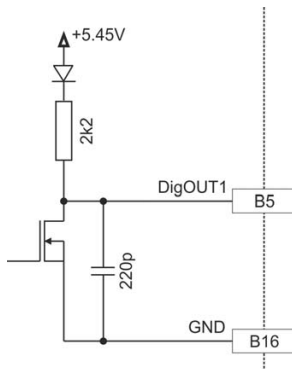


Figure 3-43 DigOUT1 circuit (analogously valid for DigOUT2 and Compact)

Continued on next page.

WIRING EXAMPLES

DigOUT “sinks”	
Max. input voltage	+36 VDC
Max. load current	500 mA
Max. voltage drop	0.5 V @ 500 mA
Max. load inductance	100 mH @ 24 VDC; 500 mA

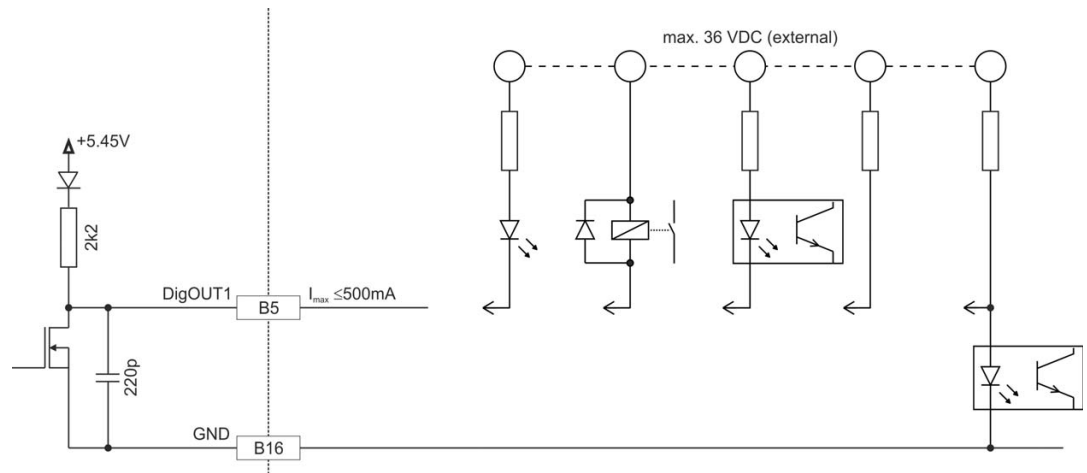


Figure 3-44 DigOUT1 “sinks” (analogously valid for DigOUT2 and Compact)

DigOUT “source”	
Output voltage	$U_{Out} = 5.45\text{ V} - 0.75\text{ V} - (I_{Load} \times 2200\ \Omega)$
Max. load current	$I_{Load} \leq 2\text{ mA}$

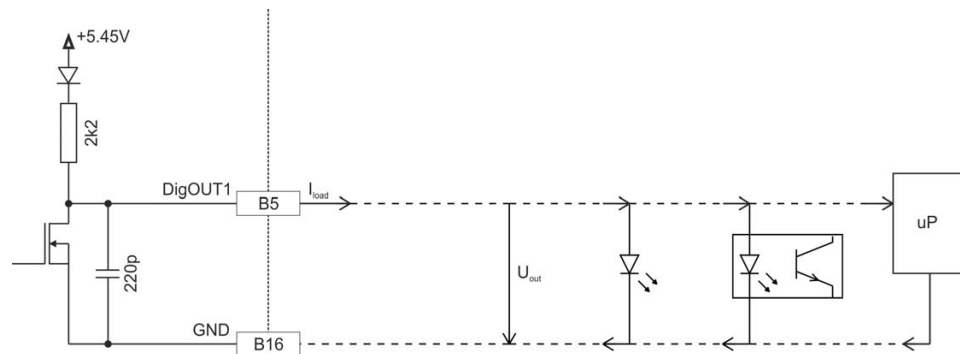


Figure 3-45 DigOUT1 “source” (analogously valid for DigOUT2 and Compact)

3.4.8 Safe Torque Off I/Os

The STO (Safe Torque Off) function can be utilized to bring the drive to a torque-free, safe condition via two independent inputs. The drive output power stage is switched off if either one of the inputs is not powered.

For in-depth details on the STO functionality → separate document «EPOS4 Application Notes».



Activation of power stage

In order to activate the power stage, **both** STO inputs must be powered.

Module Header Pin	Compact/CB Connector Pin	Signal	Description
–	X9 8	V_{STO}	Activation voltage for STO inputs (+5 VDC) Note: Do not use this voltage for any other purpose
B15	–	V_{Aux}	Auxiliary output voltage (+5 VDC; $I_L \leq 150$ mA)
B16	X9 7	GND	Ground
B17	X9 1	STO-IN1+	Safe Torque Off input 1, positive signal
B18	X9 2	STO-IN1–	Safe Torque Off input 1, negative signal
B19	X9 3	STO-IN2+	Safe Torque Off input 2, positive signal
B20	X9 4	STO-IN2–	Safe Torque Off input 2, negative signal
B21	X9 5	STO-OUT+	Safe Torque Off output, positive signal
B22	X9 6	STO-OUT–	Safe Torque Off output, negative signal

Table 3-59 STO I/Os – Pin assignment

Safe Torque Off inputs 1...2	
Circuit type	Optically isolated input
Input voltage	0...+30 VDC
Max. input voltage	±30 VDC
Logic 0	<1.0 VDC
Logic 1	>4.5 VDC
Input current at logic 1	>2 mA @ 5 VDC typically 3.2 mA @ 24 VDC
Reaction time	<25 ms

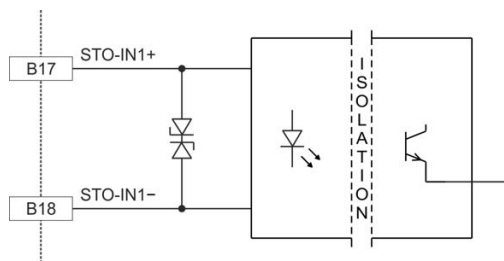


Figure 3-46 STO-IN1 circuit (analogously valid for STO-IN2)

Safe Torque Off output	
Circuit type	Optically isolated output with self-resetting short-circuit protection
Max. input voltage	±30 VDC
Max. load current	15 mA
Leakage current	<10 µA @ +30 VDC
Max. voltage drop	1.3 V @ 2 mA 2.5 V @ 15 mA

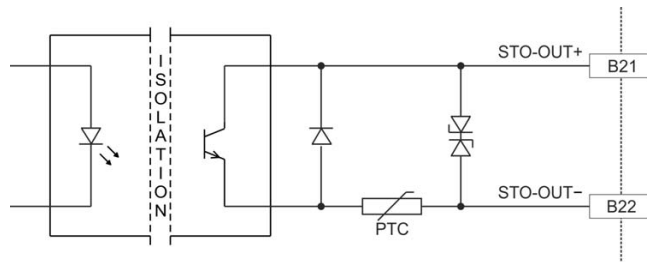


Figure 3-47 STO-OUT circuit

STO Logic State			
STO-IN1	STO-IN2	STO-OUT	Power Stage
0	0	open	inactive
1	0	closed	inactive
0	1	closed	inactive
1	1	closed	active

Table 3-60 STO logic state

3.4.9 Analog I/Os

Module Header Pin	Compact/CB Connector Pin	Signal	Description
B16	X8 7	GND	Ground
B23	X8 1	AnIN1+	Analog input 1, positive signal
B24	X8 2	AnIN1-	Analog input 1, negative signal
B25	X8 3	AnIN2+	Analog input 2, positive signal
B26	X8 4	AnIN2-	Analog input 2, negative signal
B27	X8 5	AnOUT1	Analog output 1
B28	X8 6	AnOUT2	Analog output 2

Table 3-61 Analog I/Os – Pin assignment

Analog inputs 1...2	
Input voltage	±10 VDC (differential)
Max. input voltage	±24 VDC
Common mode voltage	-5...+10 VDC (referenced to GND)
Input resistance	80 kΩ (differential) 65 kΩ (referenced to GND)
A/D converter	12-bit
Resolution	5.64 mV
Bandwidth	10 kHz

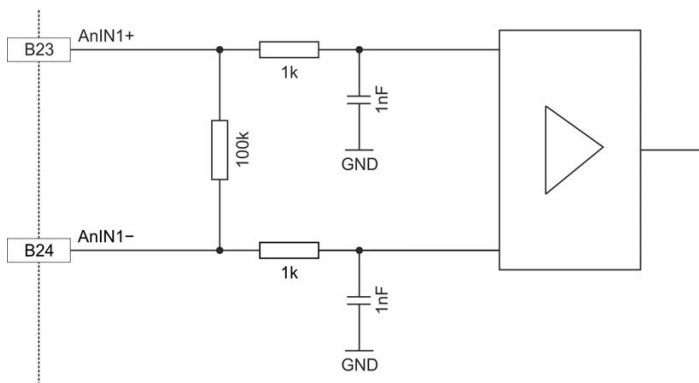


Figure 3-48 AnIN1 circuit (analogously valid for AnIN2)

Analog outputs 1...2	
Output voltage	±4 VDC
D/A converter	12-bit
Resolution	2.42 mV
Refresh rate	2.5 kHz
Analog bandwidth of output amplifier	25 kHz
Max. capacitive load	300 nF Note: The increase rate is limited in proportion to the capacitive load (e.g. 5 V/ms @ 300 nF)
Max. output current limit	1 mA

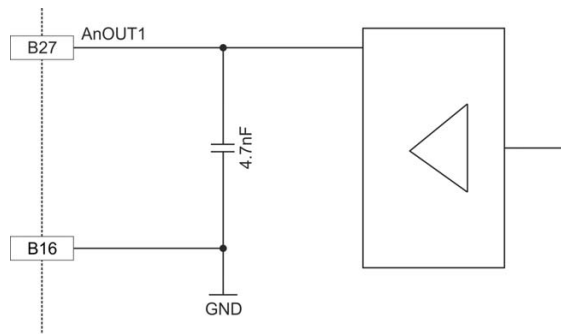


Figure 3-49 AnOUT1 circuit (analogously valid for AnOUT2)

3.4.10 Serial Communication Interface (SCI) / RS232

The SCI is a two-wire asynchronous serial port, commonly known as a UART. The SCI modules support digital communication between the CPU and other asynchronous peripherals that use the standard non-return-to-zero (NRZ) format.

A common use of the Module's SCI is to build an RS232 interface by wiring it to an RS232 transceiver. Alternatively, using any of the Compact versions does not require an external transceiver.



Bit rate settings

- Consider the master's maximal bite rate.
- The standard bit rate setting (factory setting) is 115'200 bit/s.

3.4.10.1 Module

Module Header Pin	Signal	Description
B38	GND	Ground
B39 ⁽⁶⁾	DSP_RxD	Serial communication interface receive (UART)
B40	DSP_TxD	Serial communication interface transmit (UART)
6) connect to sensor supply voltage V_{Sensor} (A40) when RS232 is not in use		

Table 3-62 SCI – Pin assignment

Serial Communication Interface (SCI)	
Input voltage	0...3.3 VDC
Max. input voltage	5 VDC
High-level input voltage	>2.0 VDC
Low-level input voltage	<0.8 VDC
High-level output voltage	>2.4 VDC
Low-level output voltage	<0.4 VDC
Max. bit rate	115'200 bit/s
Data format	NRZ (non-return-to-zero)

3.4.10.2 Compact

Compact/CB Connector Pin	Signal	Description
X10 1	EPOS_RxD	EPOS RS232 receive
X10 2	GND	Ground
X10 3	EPOS_TxD	EPOS RS232 transmit
X10 4	GND	Ground
X10 5	Shield	Cable shield

Table 3-63 RS232 – Pin assignment

RS232 Interface	
Max. input voltage	±30 VDC
Output voltage	typically ±9 V @ 3 kΩ to GND
Max. bit rate	115'200 bit/s
RS232 transceiver	EIA RS232 standard

3.4.11 CAN Interface

3.4.11.1 Connection

The EPOS4 is specially designed being commanded and controlled via a Controller Area Network (CAN), a highly efficient data bus very common in all fields of automation and motion control. It is preferably used as a slave node in the CANopen network.

Module Header Pin	Compact/CB Connector Pin	Signal	Description
B35	X11 1 X12 1	CAN high	CAN high bus line
B36	X11 2 X12 2	CAN low	CAN low bus line
B37	X11 3 X12 3	GND	Ground
–	X11 4 X12 4	Shield	Cable shield

Table 3-64 CAN bus line / CAN 1 / CAN 2 – Pin assignment

CAN interface		
Standard	ISO 11898-2:2003	
Max. bit rate	1 Mbit/s	
Max. number of CAN nodes	127/31 (via software/hardware setting)	
Protocol	CiA 301 version 4.2.0	
Identifier setting	Module	By external wiring or software
	Compact	By DIP switch or software



Note

- Consider the CAN master's maximal bit rate.
- The standard bit rate setting (factory setting) is 1 Mbit/s. For connector boards and Compact versions, automatic bit rate detection is set.
- Use 120 Ω termination resistor at both ends of the CAN bus.
- For detailed CAN information → separate document «EPOS4 Communication Guide».

3.4.11.2 Configuration

For Compact version's CAN configuration → "DIP Switch Configuration (SW1)" on page 3-39.

CAN ID (NODE ADDRESS)

The CAN ID is set with input lines CAN ID1...CAN ID5. The node address (1...31) may be coded using binary code.

Module Header Pin	Signal	Description	Binary Code	Valence
B29	CAN ID 1	CAN ID 1	2 ⁰	1
B30	CAN ID 2	CAN ID 2	2 ¹	2
B31	CAN ID 3	CAN ID 3	2 ²	4
B32	CAN ID 4	CAN ID 4	2 ³	8
B33	CAN ID 5	CAN ID 5	2 ⁴	16
B37	GND	Ground		

Table 3-65 CAN ID – Pin assignment

CAN ID	
Max. input voltage	3.3 VDC
Logic 1	connected to GND
Logic 0	not connected

The set CAN ID (node address) can be observed by adding the valences of all inputs connected externally to GND. Use the following table as a (non-concluding) guide:

CAN ID					Node Address
1	2	3	4	5	
0*	0	0	0	0	–
1**	0	0	0	0	1
0	1	0	0	0	2
0	0	1	0	0	4
1	0	1	0	0	5
0	0	0	1	0	8
0	0	0	0	1	16
1	1	1	1	1	31

0* = CAN ID input line not connected 1** = CAN ID input line externally connected to GND

Table 3-66 CAN ID – Examples



Setting the CAN ID by «EPOS Studio»

- The CAN ID may be set by software (changing object "Node ID", range 1...127).
- The CAN ID set by the software is valid if the Node Address is set to "0" (all CAN ID input lines not connected).

CAN AUTOMATIC BIT RATE DETECTION

With this function, the CANopen interface can be put in a “listen only” mode. For further details → separate document «EPOS4 Firmware Specification». Automatic bit rate detection is activated when the input line is externally connected to GND.

Bit rate detection	
Auto Bit Rate GND	Pin B34 Pin B38
Max. input voltage	3.3 VDC
Logic 1	connected to GND
Logic 0	not connected

3.4.12 Serial Peripheral Interface (SPI)

The SPI is a high-speed synchronous serial input/output port allowing the use of optional maxon extension modules.



Note

Do not connect any other signals to the SPI apart from those for the maxon extension modules!

Module Header Pin	Signal	Description
B38	GND	Ground
B41	SPI_CLK	Serial Peripheral Interface clock
B42	SPI_IRQ	Serial Peripheral Interface interrupt request
B43	SPI_SOMI	Serial Peripheral Interface Slave output, Master input
B44	SPI_SIMO	Serial Peripheral Interface Slave input, Master output
B45	SPI_CS2	Serial Peripheral Interface chip select 2
B46	SPI_CS1	Serial Peripheral Interface chip select 1

Table 3-67 SPI – Pin assignment

3.4.13 USB (X13)



Hot plugging the USB interface may cause hardware damage

If the USB interface is being hot-plugged (connecting while the power supply is on), the possibly high potential differences of the two power supplies of controller and PC/Notebook can lead to damaged hardware.

- Avoid potential differences between the power supply of controller and PC/Notebook or, if possible, balance them.
- Insert the USB connector first, then switch on the power supply of the controller.

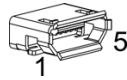


Figure 3-50 USB connector X13

Compact/CB Connector Pin	PC's USB Terminal	Signal	Description
X13 1	1	V _{BUS}	USB bus supply voltage input +5 VDC
X13 2	2	USB_D-	USB Data- (twisted pair with Data+)
X13 3	3	USB_D+	USB Data+ (twisted pair with Data-)
X13 4	–	ID	not connected
X13 5	4	GND	USB ground

Table 3-68 USB connector X13 – Pin assignment

USB Type A - micro B Cable (403968)	
Cross-section	According to USB 2.0 / USB 3.0 specification
Length	1.5 m
Head A	USB Type "micro B", male
Head B	USB Type "A", male

Table 3-69 USB Type A - micro B Cable

USB	
USB Standard	USB 2.0 / USB 3.0 (full speed)
Max. bus supply voltage	+5.25 VDC
Max. DC data input voltage	-0.5...+3.8 VDC

3.5 Status Indicators

The EPOS4 features LED indicators to display the device condition. For detailed information → separate document «EPOS4 Firmware Specification».

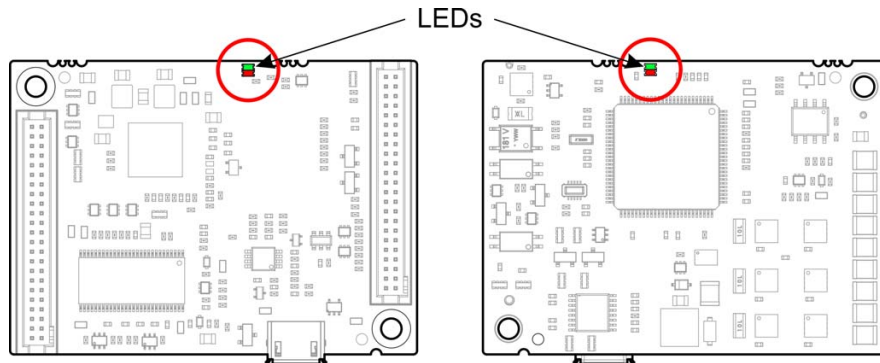


Figure 3-51 Status LED

The LEDs display the actual status and possible errors of the EPOS4:

- Green LED shows the status
- Red LED indicates errors

LED		Status / Error
Green	Red	
Slow	OFF	Power stage is disabled. The EPOS4 is in status... • “Switch ON Disabled” • “Ready to Switch ON” • “Switched ON”
ON	OFF	Power stage is enabled. The EPOS4 is in status... • “Operation Enable” • “Quick Stop Active”
OFF	ON	FAULT state. The EPOS4 is in status... • “Fault”
ON	ON	Power stage is enabled. The EPOS4 is in temporary status... • “Fault Reaction Active”
Flash	ON	No valid firmware or firmware download in progress
Flash = Flashing (≈0.9 s OFF/≈0.1 s ON)		Slow = Slow blinking (≈1 Hz)

Table 3-70 Status LED

4 Motherboard Design Guide

The «Motherboard Design Guide» provides helpful information on integrating the Module on a printed circuit board. It contains recommendations for the motherboard layout and specifies external components that may be required, pin assignments, and connection examples.



CAUTION

Dangerous Action

Errors in implementing the design can result in serious Injury!

- *Only proceed if you are skilled in electronics design!*
- *Designing a printed circuit board requires special skills and knowledge and may only be performed by experienced electronic developers!*
- *This quick guide is only intended as an aid, does not make any claim to completeness, and will not automatically result in a functional component!*



Get help

*If you are not trained in the design and development of printed circuit boards, you will need additional support for this point.
maxon motor will be happy to provide you with a quote for designing and manufacturing a motherboard for your specific application.*

4.1 Requirements for Components of Third-party Suppliers



Best practice

For references and recommended components consult →Table 4-71.

4.1.1 Socket Headers

For implementation of the Module, 1.27 mm box headers are required.

4.1.2 Supply Voltage

To protect the Module, we recommend using an external circuit breaker, a TVS diode, and a capacitor in the voltage supply cable. In this regard, please note the following recommendations:

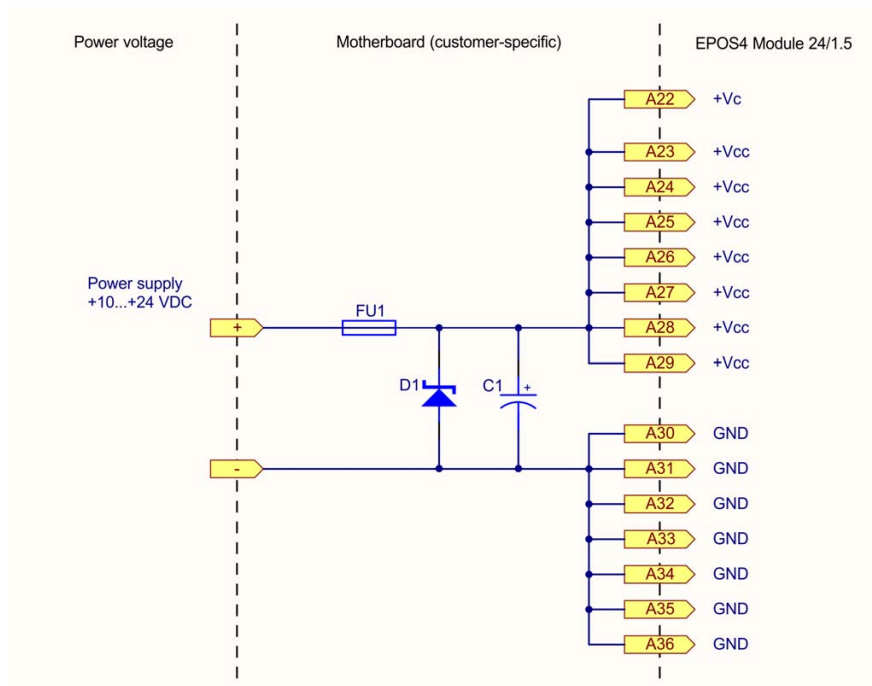


Figure 4-52 Wiring of power supply

INPUT FUSE (FU1)

An input fuse (FU1) is necessary in order to provide reverse polarity protection. Together with an unipolar TVS diode (D1), this prevents current from flowing in the wrong direction.

TVS DIODE (D1)

To protect against overvoltage resulting from voltage transients or brake energy feedback, we recommend connecting a TVS (transient voltage suppressor) diode (D1) to the voltage supply line.

CAPACITOR (C1)

The function of the Module does not necessarily require the use of an external capacitor. Nevertheless, to further reduce voltage ripple and feedback currents, an electrolytic capacitor (C1) can be connected to the voltage supply line. Use of an electrolytic capacitor is also recommended to avoid oscillations caused by supply cable inductance or Module's built-in capacitors that could lead to a voltage overshoot at power plug-in.

4.1.3 Logic Supply Voltage

The Module features a logic supply voltage input. Its voltage range is 10...24 V and must be either sourced separately or by the power supply voltage.

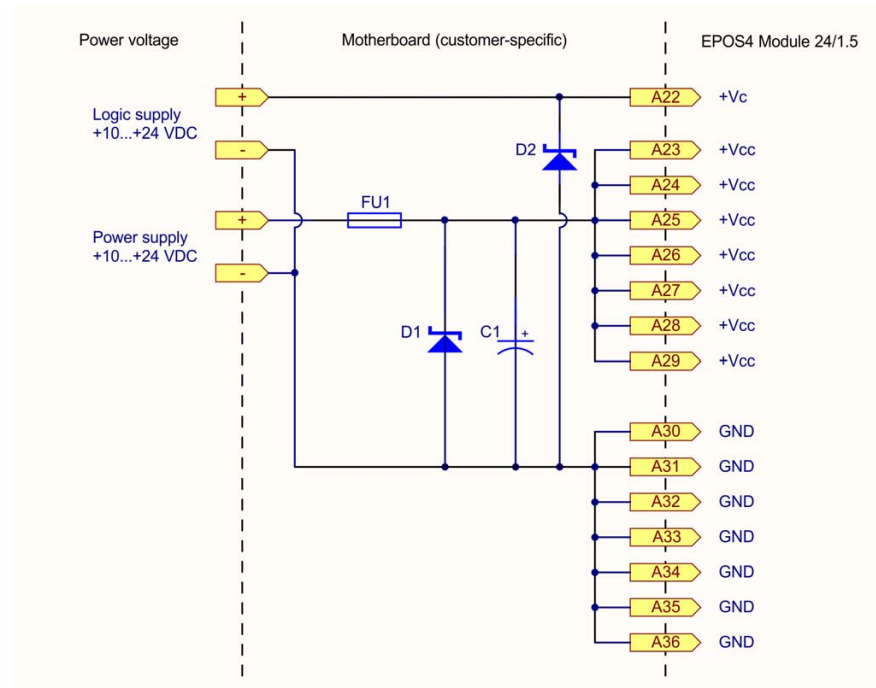


Figure 4-53 Wiring of logic supply

TVS DIODE (D2)

If the logic supply voltage is sourced separately, a transient voltage suppressor diode (D2) at the logic supply voltage input can be connected to protect the module against overvoltage.

4.1.4 Motor Cables and Motor Chokes

The Module is not equipped with internal motor chokes.

The majority of motors and applications do not require additional chokes. However, in case of high supply voltage with very low terminal inductance, the ripple of the motor current can reach an unacceptably high value. This causes the motor to heat up unnecessarily and causes instable control behavior. The minimum terminal inductance required per phase can be calculated using the following formula:

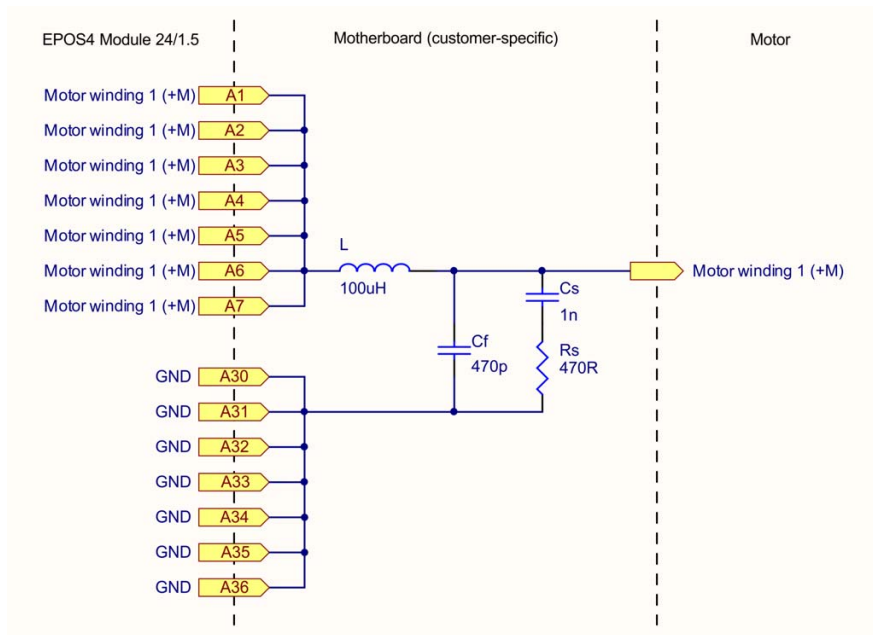
$$L_{Phase} \geq \frac{1}{2} \cdot \left(\frac{V_{CC}}{6 \cdot f_{PWM} \cdot I_N} - (0.3 \cdot L_{Motor}) \right)$$

$L_{Phase}[H]$	Additional external inductance per phase
$V_{CC}[V]$	Operating voltage +V _{cc}
$f_{PWM}[Hz]$	Switching frequency of the power stage = 100'000 Hz
$I_N[A]$	Nominal current of the motor (→line 6 in the maxon catalog)
$L_{Motor}[H]$	Terminal inductance of the motor (→line 11 in the maxon catalog)

If the result of the calculation is negative, no additional chokes are necessary. Nevertheless, the use of chokes in combination with additional filter components can be useful to reduce the emission of electromagnetic interference.

An additional choke must feature electromagnetic shielding, an adequate saturation current, minimal losses, and a nominal current greater than the continuous current of the motor. The below wiring example refers to an additional inductance of 100 μH or 10 μH . If a different additional inductance is required, also the filter components must be adapted accordingly. Should you need further help with the filter design, contact maxon Support at <http://support.maxonmotor.com>.

Example 1



Example 2

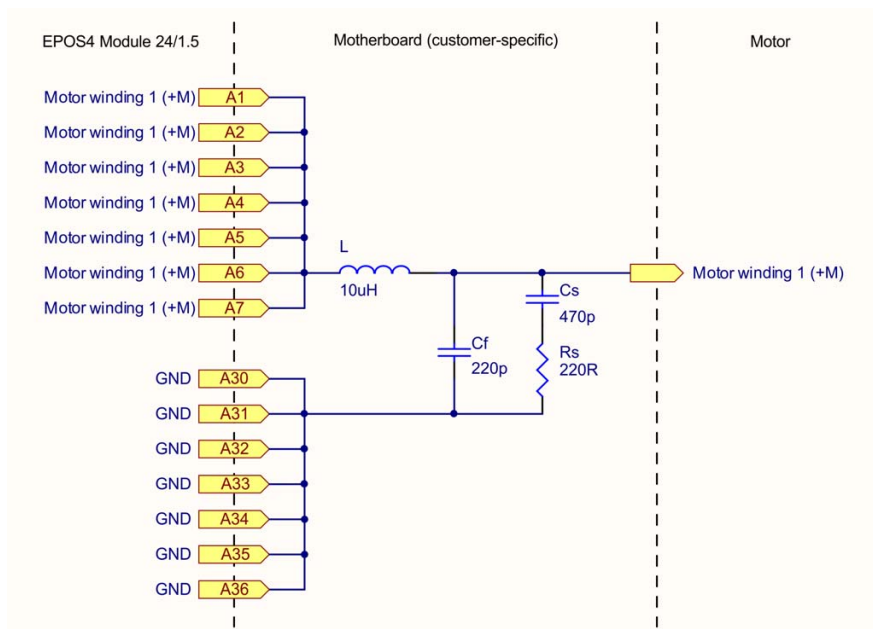


Figure 4-54 Wiring of motor winding 1 (analogously valid also for motor windings 2 & 3)

4.1.5 RS232 Transceiver

If you intend to use an RS232 interface, an external transceiver is necessary.

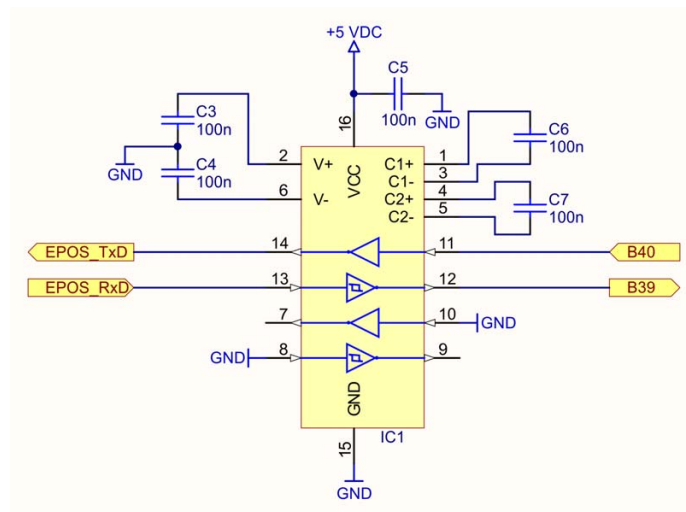


Figure 4-55 Wiring of RS232 transceiver



IMPORTANT

If you do not intend to use the RS232 interface, you are recommended to connect pin [B39] to pin [A40] (sensor supply voltage V_{Sensor})!

4.1.6 Recommended Components and Manufacturers

Recommended components	
Socket header	Dual row socket strip, pluggable, 1.27 mm pitch, contact length 2.9 mm, current rating per pin = $I_{cont} / 1 \text{ A}$ 23 poles, 2 rows: <ul style="list-style-type: none"> • maxon motor (590738) • E-Tec (BS2-046-H45B-55/11) • Confectronic / Elcotron (2243-A46G00DPT-M/U842)
Fuse (FU1)	<ul style="list-style-type: none"> • Littelfuse 157 Series, Fuse 6.3 A, 9.17 A²sec (015706.3)
TVS Diode (D1; D2)	<ul style="list-style-type: none"> • Vishay (SMBJ30A) $U_R = 30 \text{ V}, U_{BR} = 33.3...36.8 \text{ V @ } 1 \text{ mA}, U_C = 48.4 \text{ V @ } 12.4 \text{ A}$ • Littelfuse (SMBJ30A) $U_R = 30 \text{ V}, U_{BR} = 33.3...36.8 \text{ V @ } 1 \text{ mA}, U_C = 48.4 \text{ V @ } 12.4 \text{ A}$
Capacitor (C1)	The ripple current load for C1 depends on the motor's operating point and the power supply output capacity. Under worst case conditions however, the ripple current may reach $I_{cont} / 2$. Use capacitors with rated voltage $\geq 35 \text{ V}$ and adequate ripple current to avoid overheat or life time reduction. Example for C1 worst-case dimensioning: $I_{cont} = 1.5 \text{ A} \rightarrow$ Rubycon (35YXJ330M10X12.5); 330 μF , 35 V, 865 mA r.m.s., $\varnothing \times L$ 10 x 14 mm
Motor Choke (L)	Inductance: \rightarrow "Motor Cables and Motor Chokes" on page 4-77 Rated current: $I_{rms} \geq I_{cont}; I_{sat} \geq I_{peak}$ Construction: shielded 100 μH: <ul style="list-style-type: none"> • Eaton (35YXJ330M10X12.5) $I_{rms} 1.96 \text{ A}, I_{sat} 3.64 \text{ A}, 12.5 \times 12.5 \times 8 \text{ mm}$ • Würth (7447709101) $I_{rms} 2.5 \text{ A}, I_{sat} 3.1 \text{ A}, 12 \times 12 \times 10 \text{ mm}$ 10 μH: <ul style="list-style-type: none"> • Bourns (SRN5040-100M) $I_{rms} 2.1 \text{ A}, I_{sat} 2.3 \text{ A}, 5 \times 5 \times 4 \text{ mm}$ • Würth (74404054100) $I_{rms} 3.1 \text{ A}, I_{sat} 2.5 \text{ A}, 5 \times 5 \times 4 \text{ mm}$
Motor Filter	Example 1 <ul style="list-style-type: none"> • Motor Choke L 100 μH • Filter Capacitor Cf 470 pF, 100 V • Snubber Capacitor Cs 1 nF, 100 V • Snubber Resistor Rs 470 Ω, 0.125 W Example 2 <ul style="list-style-type: none"> • Motor Choke L 10 μH • Filter Capacitor Cf 220 pF, 100 V • Snubber Capacitor Cs 470 pF, 100 V • Snubber Resistor Rs 220 Ω, 0.25 W
RS232 (IC1) (C3...C7)	RS232 transceiver (IC1) <ul style="list-style-type: none"> • Texas Instruments (MAX202IPW) • ST Microelectronics (ST202EBTR) Capacitors (C3...C7) <ul style="list-style-type: none"> • 100 nF, X7R, 16 V

Table 4-71 Motherboard Design Guide – Recommended components

4.2 Design Guidelines

The following instructions are intended to serve as an aid when designing an application-specific motherboard and ensures the correct and reliable integration of the Module.

While designing a motherboard, consider the following characteristics of the Module:

- Pin assignment (→page 3-18)
- Technical data (→page 2-11) and dimensional drawing (→page 2-14)

4.2.1 Ground

All ground connections (GND) should be internally connected to the Module (equal potential). It is customary to equip the motherboard with a ground plane. All ground connections should be connected to the voltage supply ground via wide conductive tracks.

Pin	Signal	Description
A30...A36	GND	Ground
B16	GND	Ground
B37...B38	GND	Ground

Table 4-72 Motherboard Design Guide – Grounding

If an earth potential is in place or required, the ground plane should be connected to the earth potential via one or more capacitors. The use of ceramic capacitors with 100 nF and 100 V is recommended.

4.2.2 Layout

Guidelines for the layout of the motherboard:

- Connector pins [A23], [A24], [A25], [A26], [A27], [A28], and [A29] for +V_{CC} (nominal power supply voltage) should be connected to the fuse via wide conductive tracks.
- Connector pins [A30], [A31], [A32], [A33], [A34], [A35], [A36], [B16], [B37], and [B38] for GND (ground) should be connected with the operating voltage ground via wide conductive tracks.
- Connector pin [B39] (DSP_RxD) must be connected to [A40] (sensor supply voltage; V_{Sensor}) when RS232 is not in use.
- The width of the conductive tracks and the copper coating thickness of the conductors for supply voltage and motor depend on the current required in your application. A minimum track width of 75 mil and a minimum copper coating thickness of 35 µm are recommended.

4.3 SMT Footprint

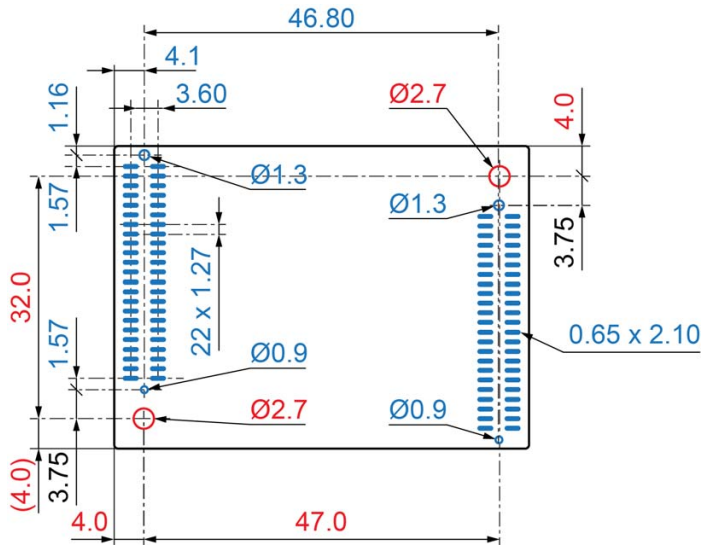


Figure 4-56 SMT footprint [mm] – Top view

5 Wiring

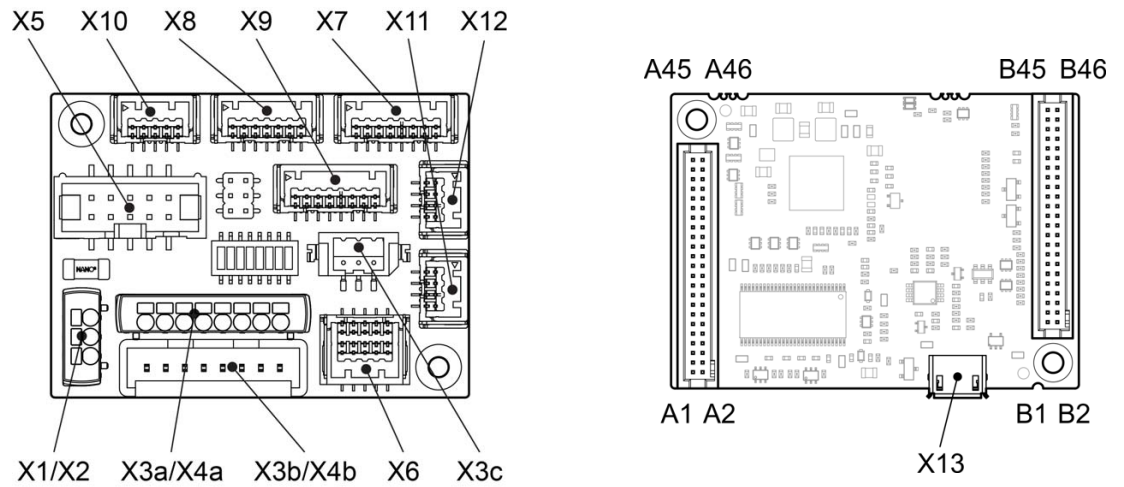


Figure 5-57 Interfaces – Designations and location



Signs and abbreviations used

The subsequent diagrams feature these signs and abbreviations:

- «EC Motor» stands for brushless EC motor (BLDC).
- Ground safety earth connection (optional).

5.1 Contents

DC Motors



Connection of DC motor with integrated motor/encoder ribbon cable

If you are using a maxon DC motor with integrated motor/encoder ribbon cable, you will need to set the jumper JP1 accordingly in order to activate that option (→chapter “3.3.7 Jumper Configuration (JP1)” on page 3-42).

DC Motor without Sensor	5-85
DC Motor – Digital Incremental Encoder	5-86
DC Motor – Digital & Digital Incremental Encoder	5-87
DC Motor – Digital & Analog Incremental Encoder	5-88
DC Motor – Digital Incremental & SSI Encoder	5-89
DC Motor – Analog Incremental Encoder	5-90
DC Motor – SSI Encoder	5-91

EC (BLDC) Motors

EC Motor – Hall Sensors	5-92
EC Motor – Hall Sensors & Digital Incremental Encoder	5-93
EC Motor – Hall Sensors & Analog Incremental Encoder	5-94
EC Motor – Hall Sensors & SSI Encoder	5-95

Continued on next page.

EC Motor – Hall Sensors & Digital & Digital Incremental Encoder	5-96
EC Motor – Hall Sensors & Digital & Analog Incremental Encoder	5-97
EC Motor – Hall Sensors & Digital Incremental & SSI Encoder	5-98
EC Motor – Digital Incremental & SSI Encoder	5-99
EC Motor – SSI Encoder	5-100

5.2 DC Motors (brushed)

5.2.1 DC Motor without Sensor

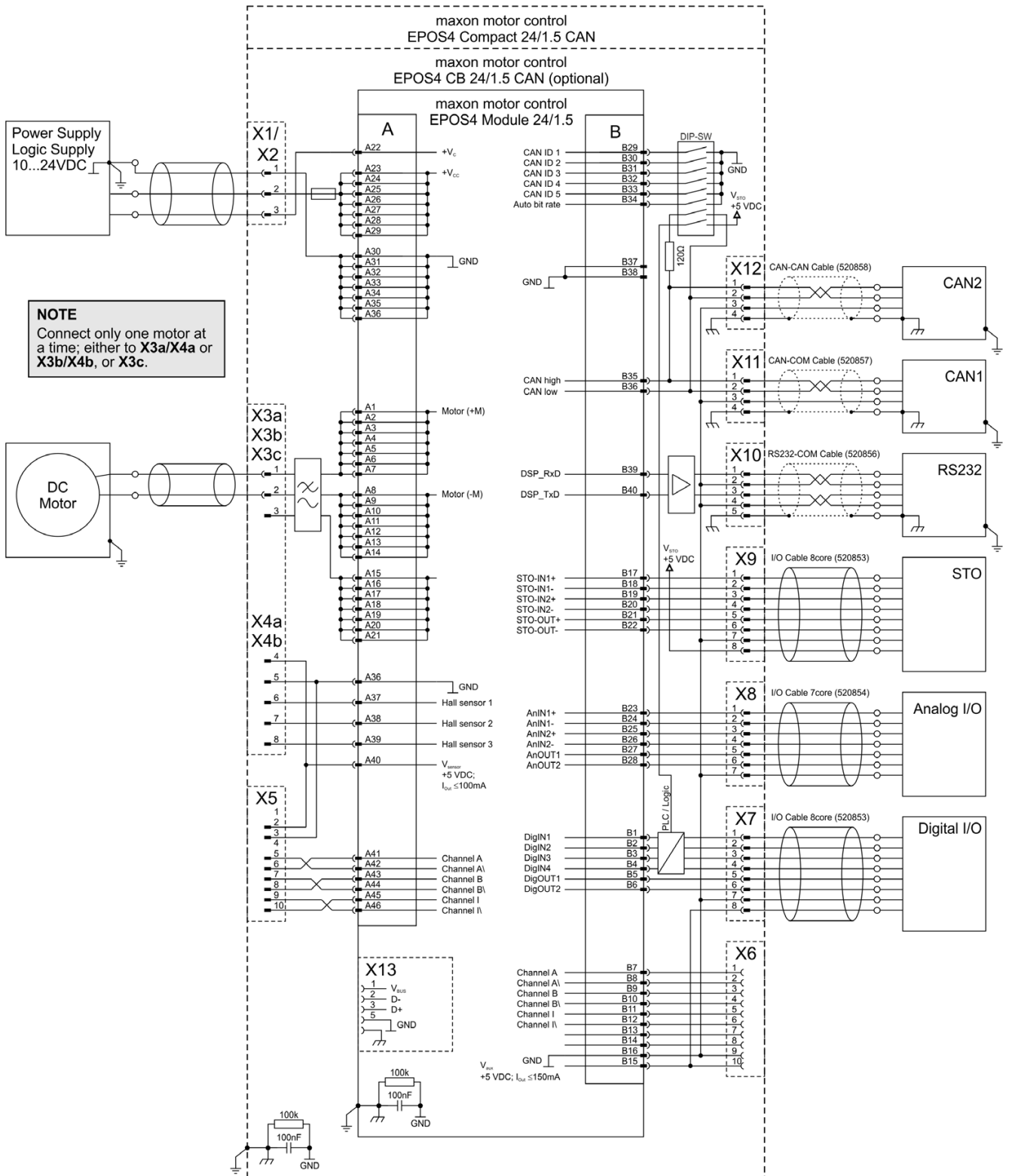


Figure 5-58 DC motor (no sensor)

5.2.2 DC Motor – Digital Incremental Encoder

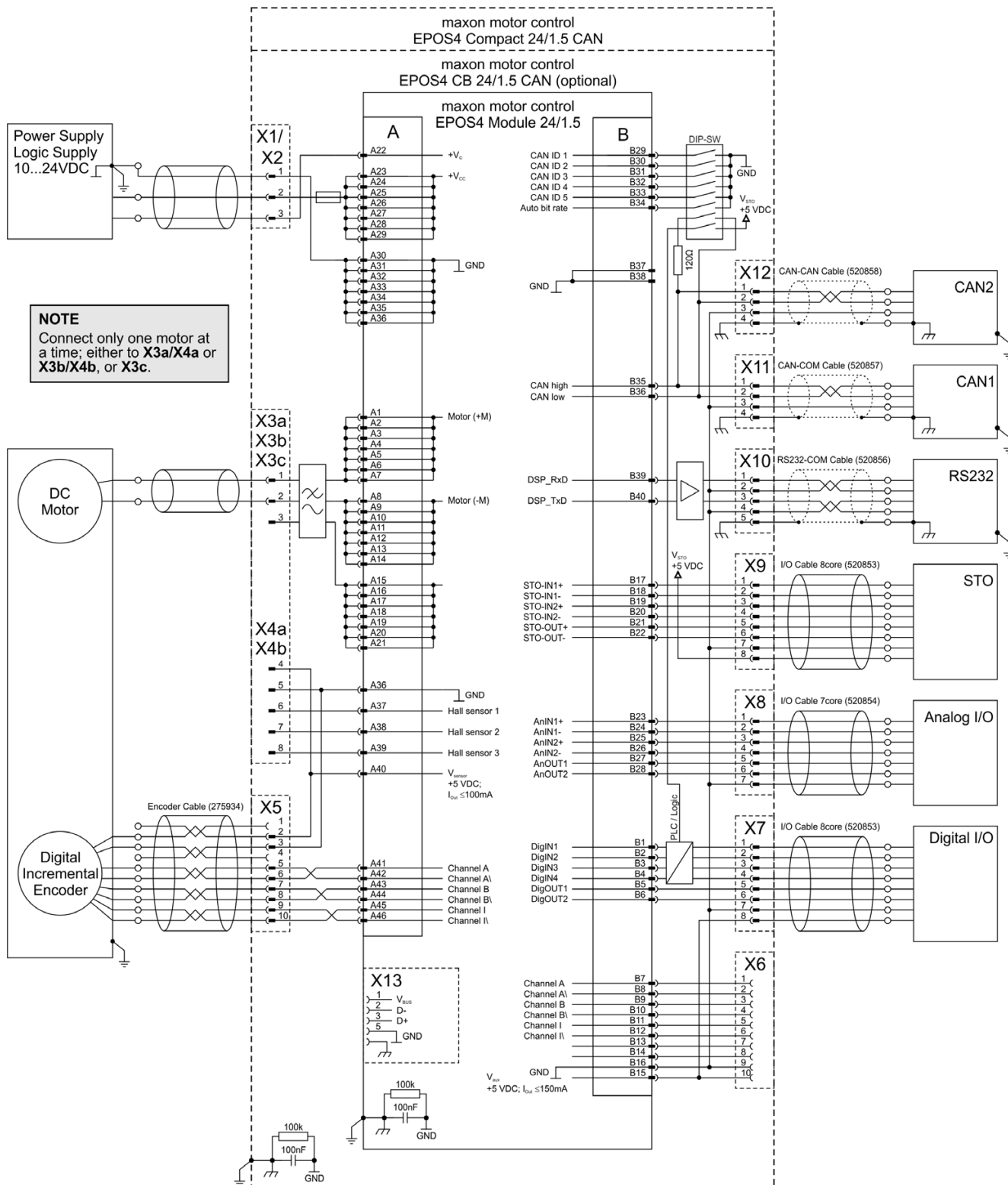


Figure 5-59 DC motor (digital incremental encoder)

5.2.3 DC Motor – Digital & Digital Incremental Encoder

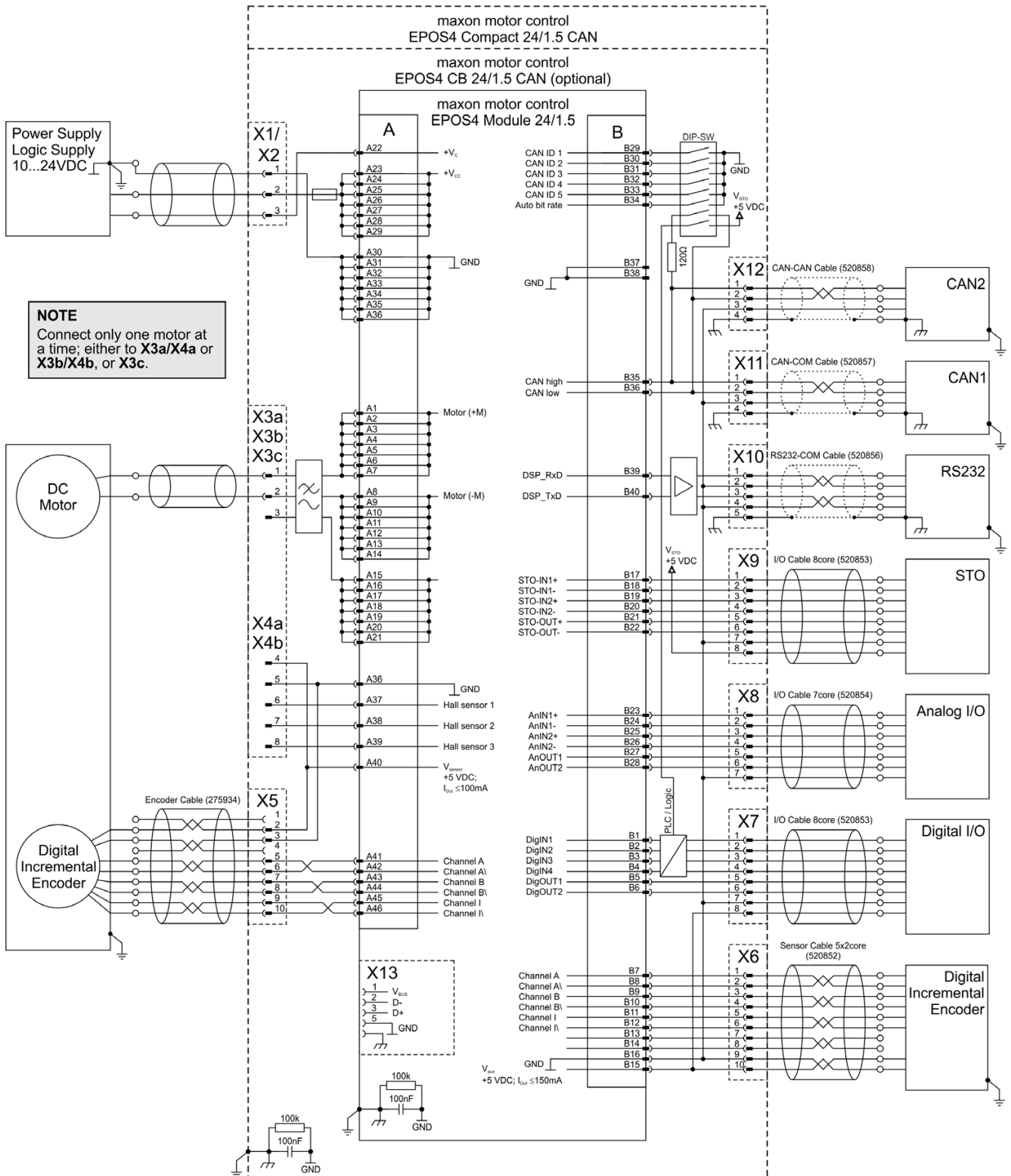


Figure 5-60 DC motor (digital & digital incremental encoder)

5.2.4 DC Motor – Digital & Analog Incremental Encoder

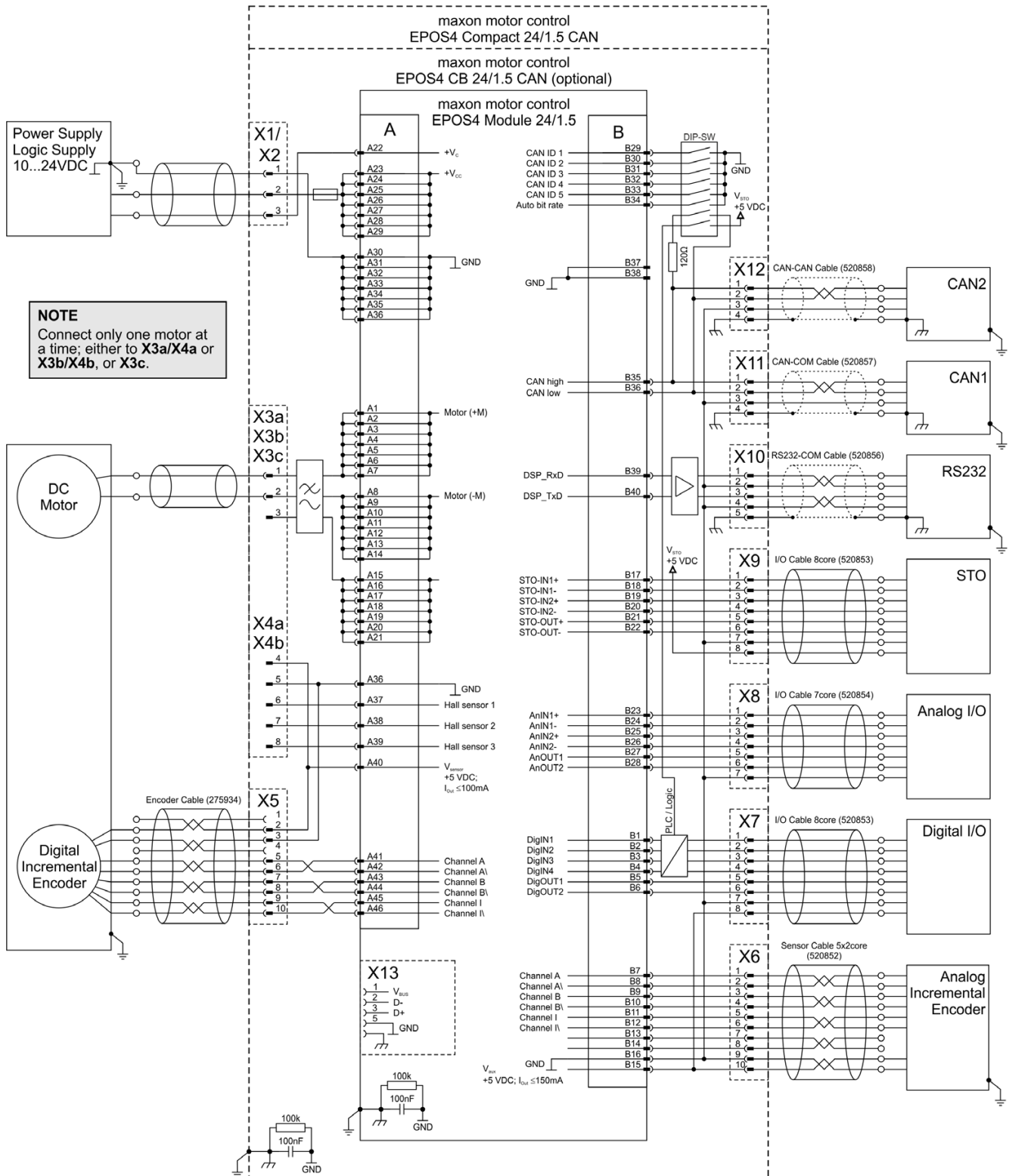


Figure 5-61 DC motor (digital & analog incremental encoder)

5.2.5 DC Motor – Digital Incremental & SSI Encoder

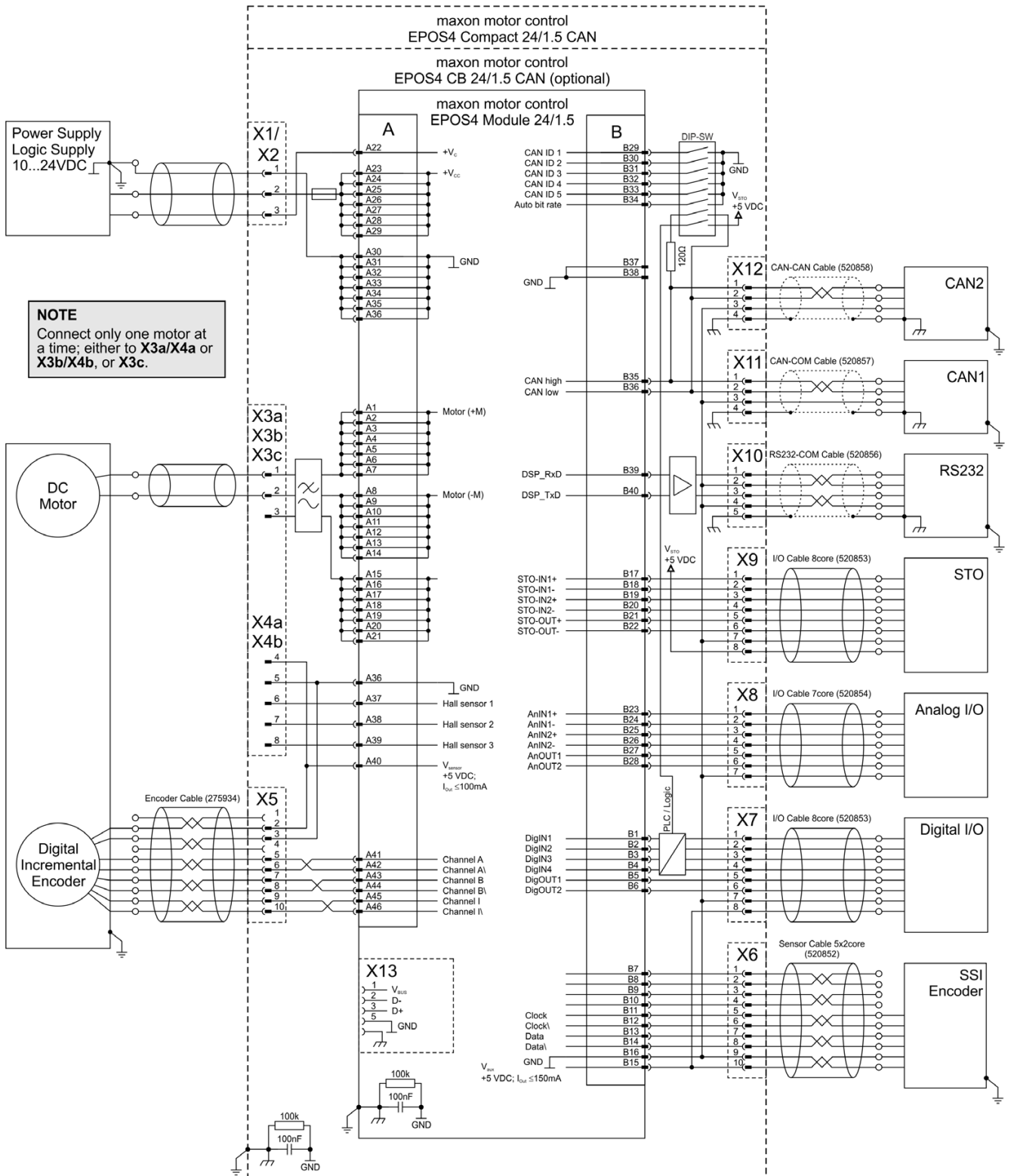


Figure 5-62 DC motor (digital incremental & SSI encoder)

5.2.6 DC Motor – Analog Incremental Encoder

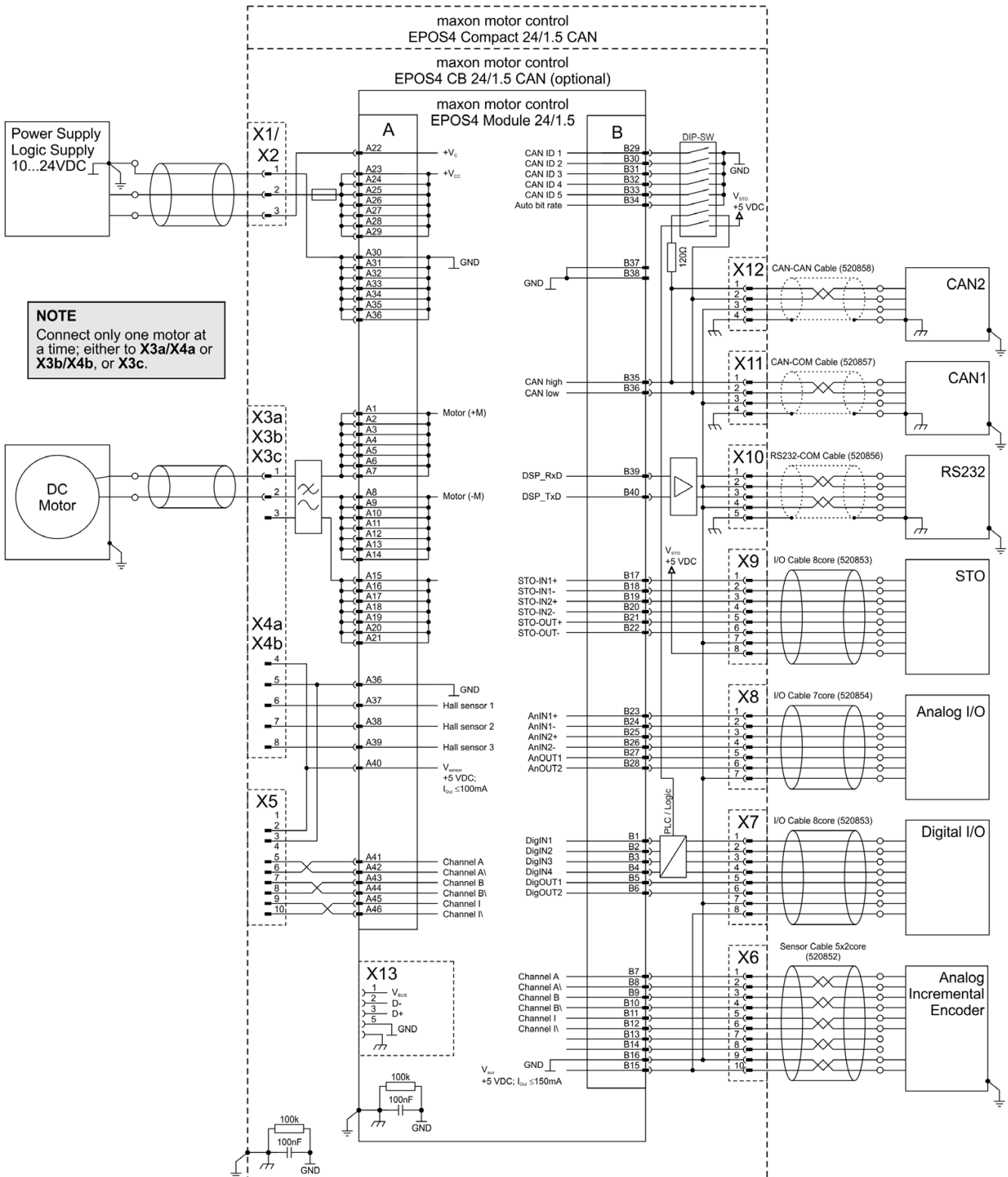


Figure 5-63 DC motor (analog incremental encoder)

5.2.7 DC Motor – SSI Encoder

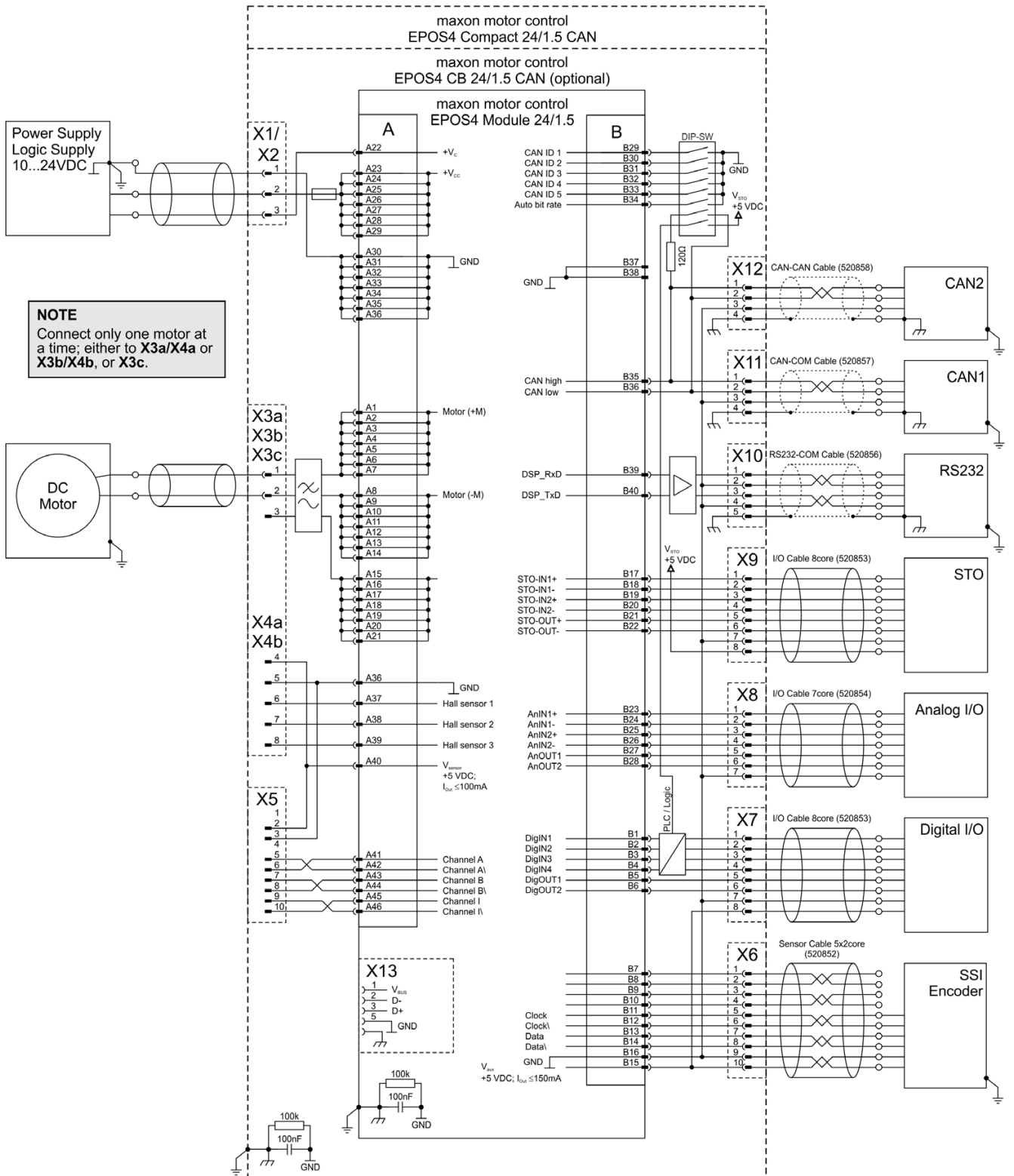


Figure 5-64 DC motor (SSI encoder)

5.3 EC Motors (BLDC, brushless)

5.3.1 EC Motor – Hall Sensors

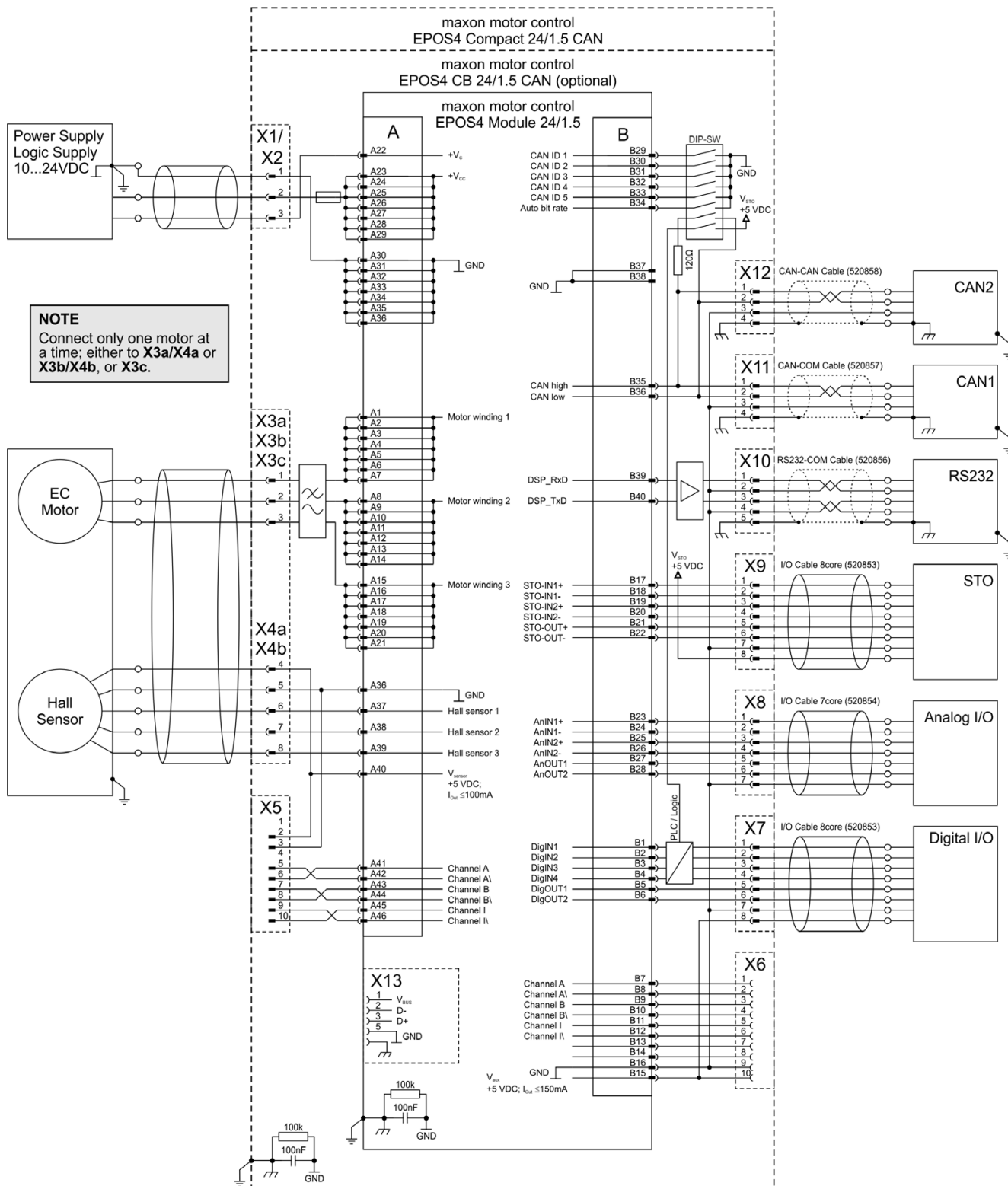


Figure 5-65 EC motor (Hall sensors)

5.3.2 EC Motor – Hall Sensors & Digital Incremental Encoder

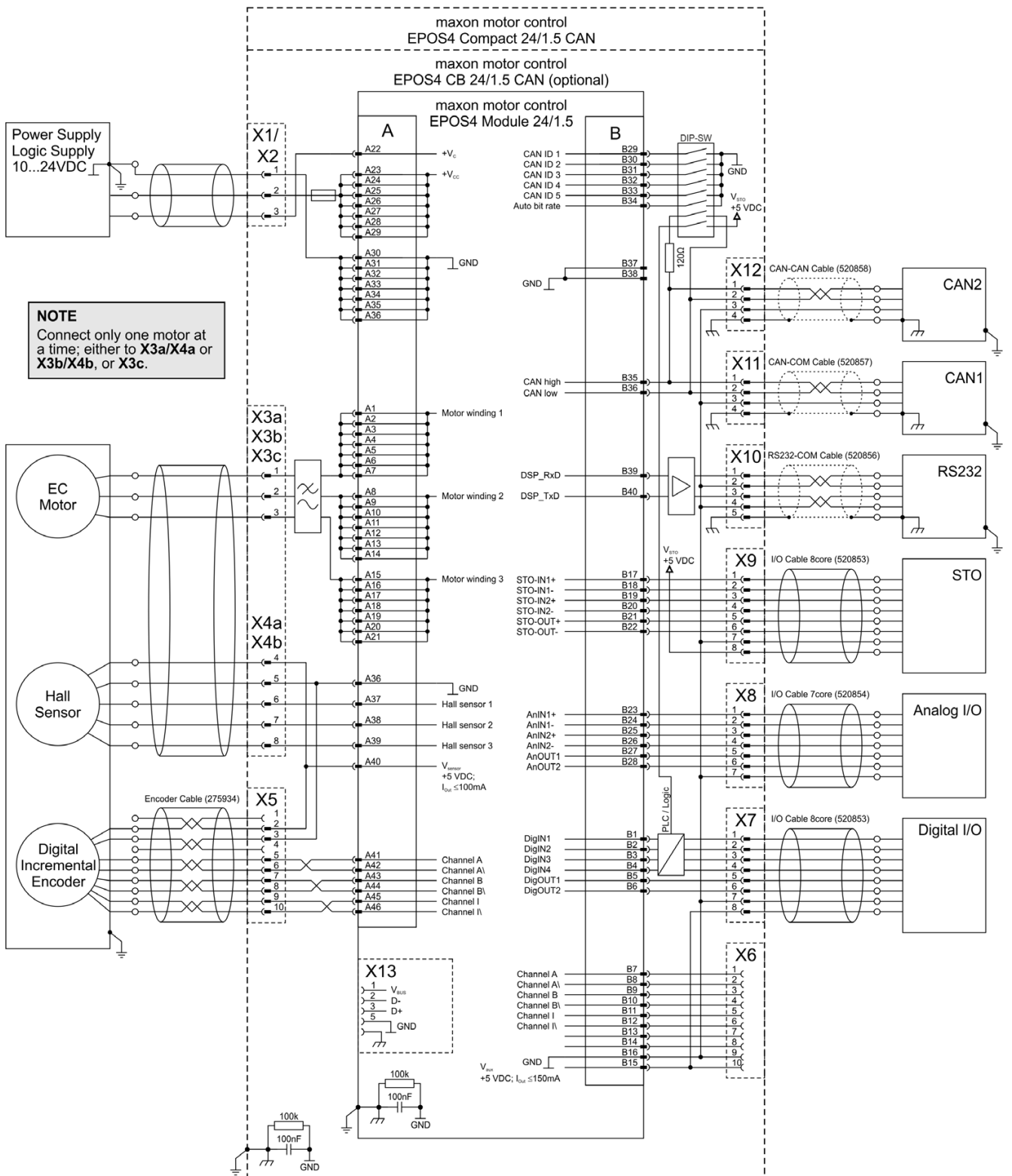


Figure 5-66 EC motor (Hall sensors & digital incremental encoder)

5.3.3 EC Motor – Hall Sensors & Analog Incremental Encoder

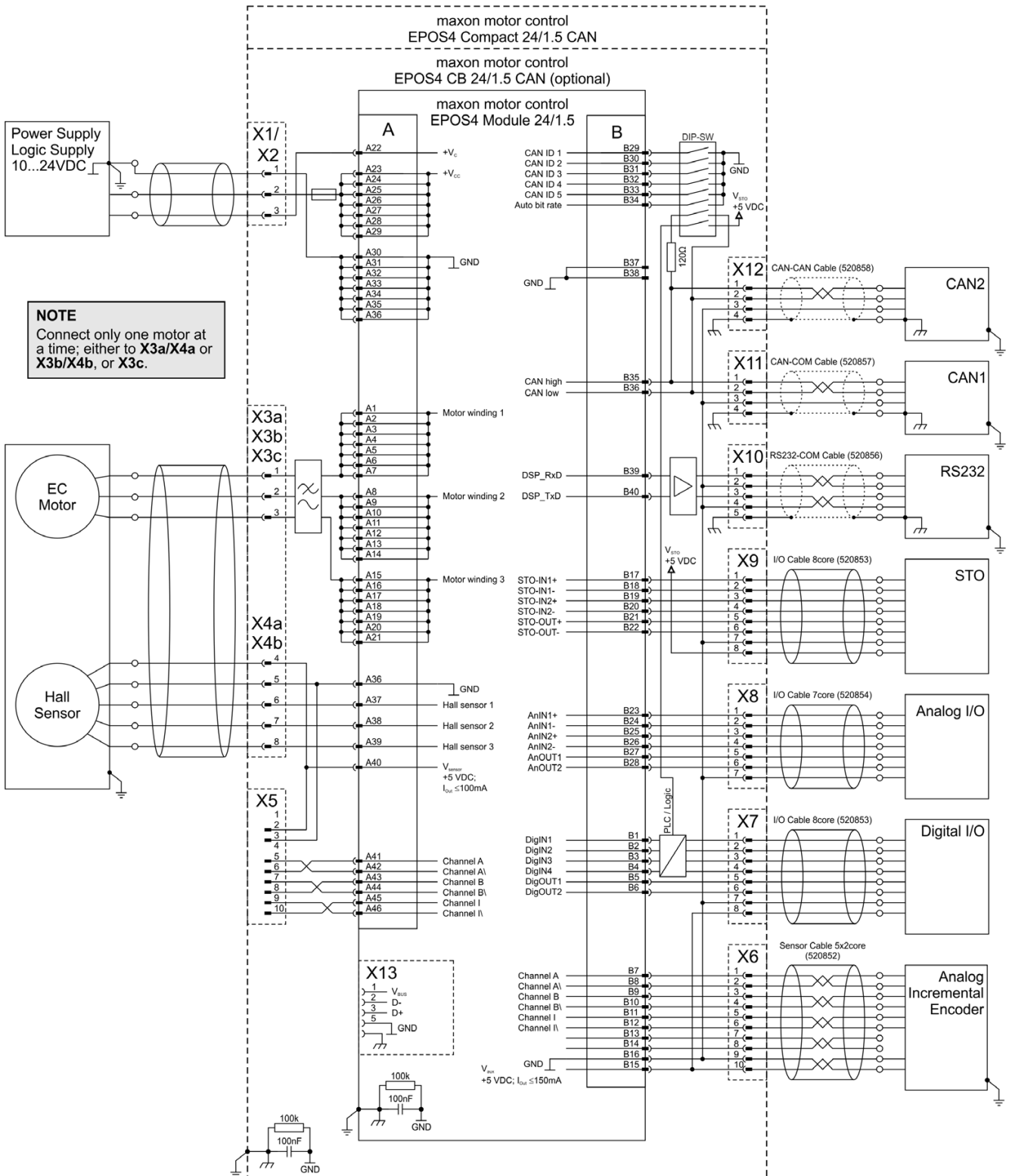


Figure 5-67 EC motor (Hall sensors & analog incremental encoder)

5.3.4 EC Motor – Hall Sensors & SSI Encoder

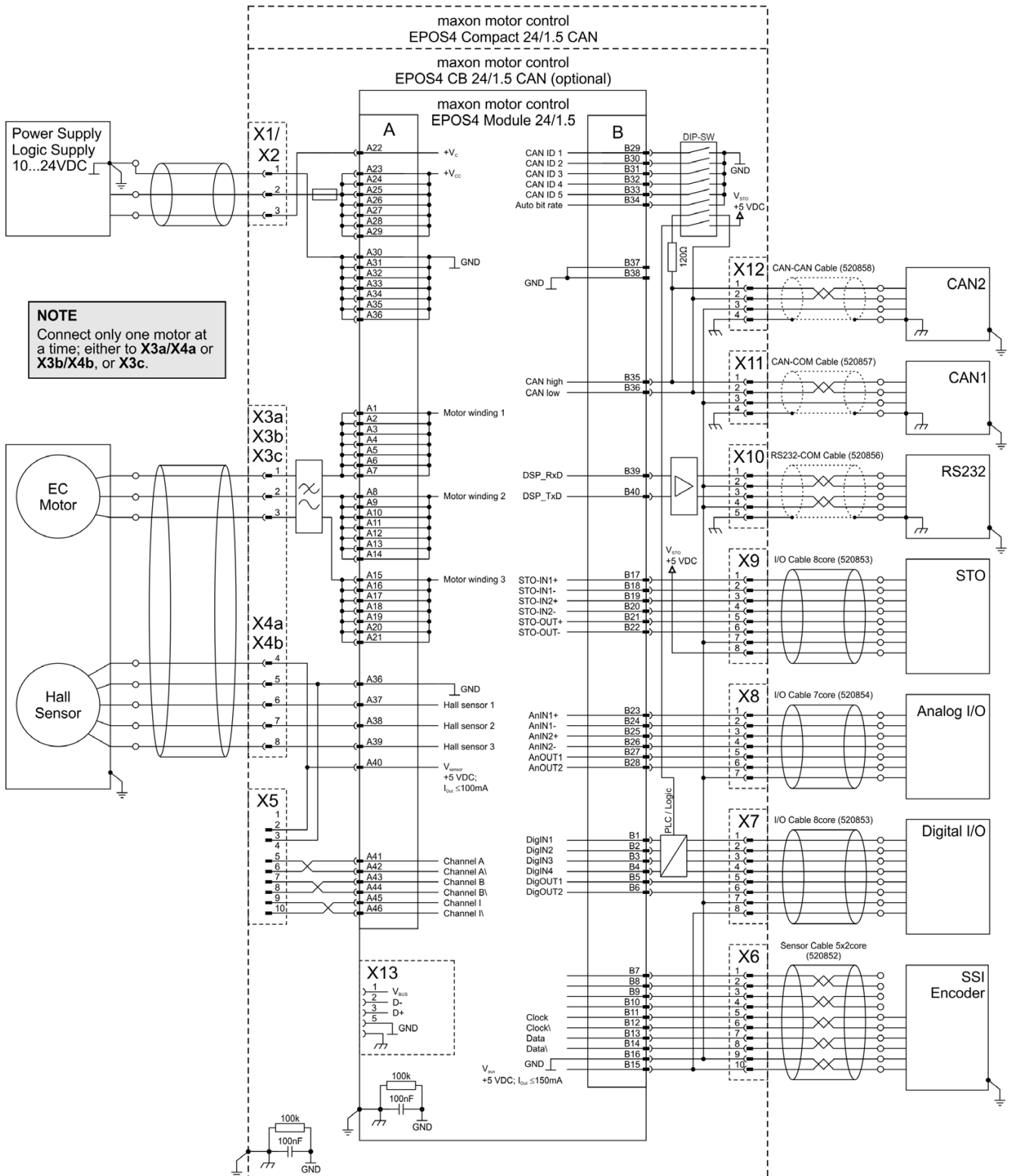


Figure 5-68 EC motor (Hall sensors & SSI encoder)

5.3.5 EC Motor – Hall Sensors & Digital & Digital Incremental Encoder

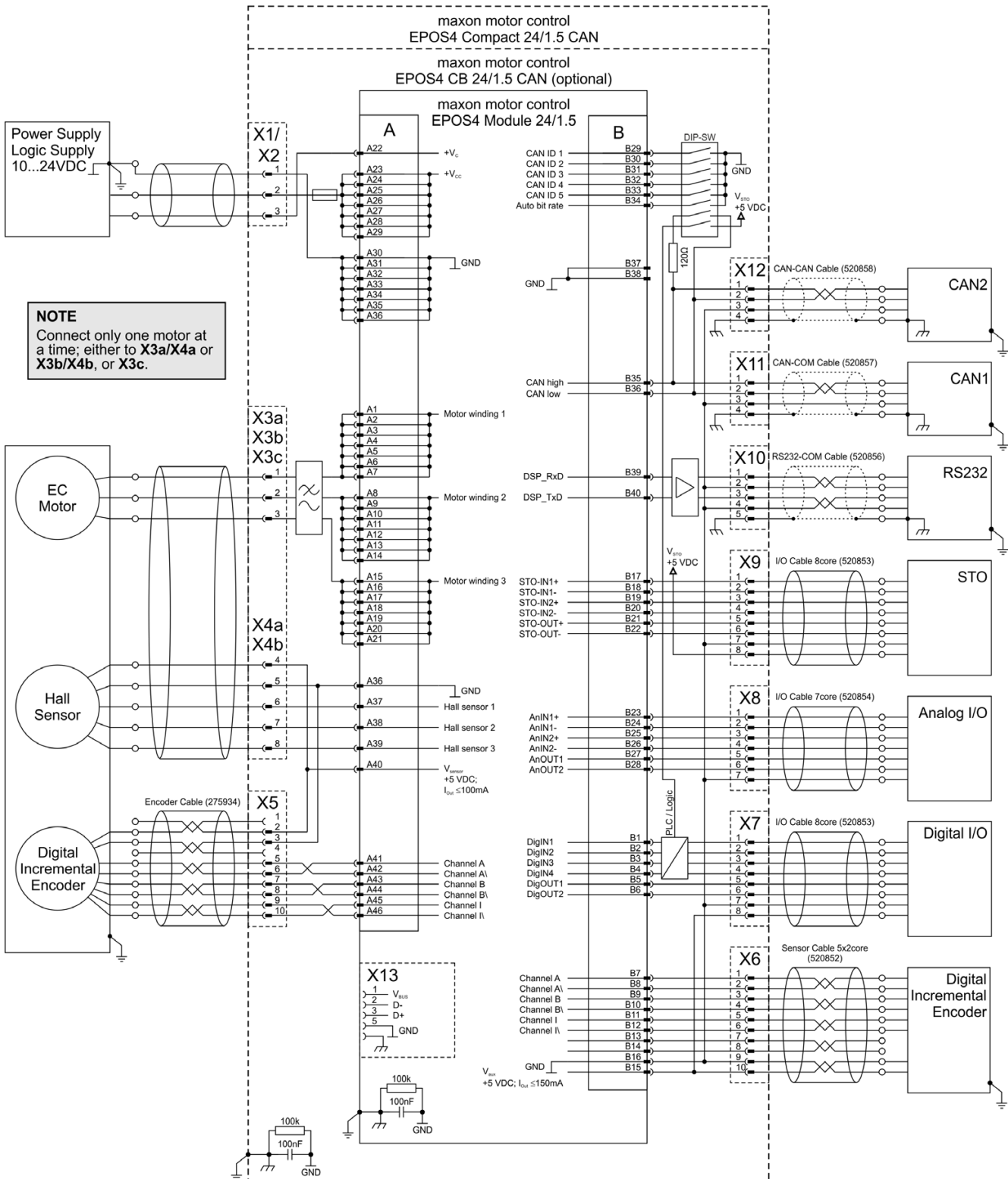


Figure 5-69 EC motor (Hall sensors & digital & digital incremental encoder)

5.3.6 EC Motor – Hall Sensors & Digital & Analog Incremental Encoder

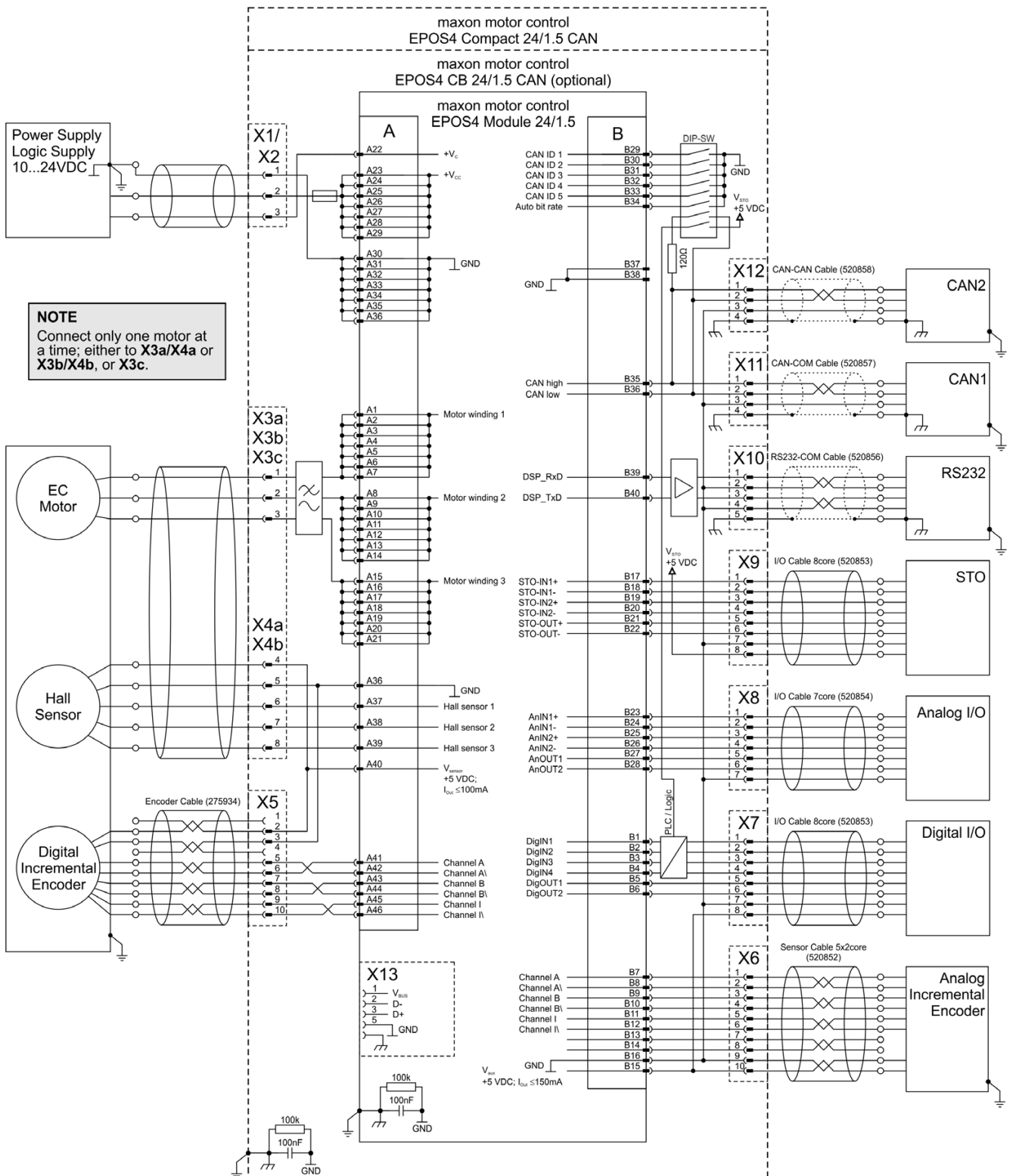


Figure 5-70 EC motor (Hall sensors & digital & analog incremental encoder)

5.3.7 EC Motor – Hall Sensors & Digital Incremental & SSI Encoder

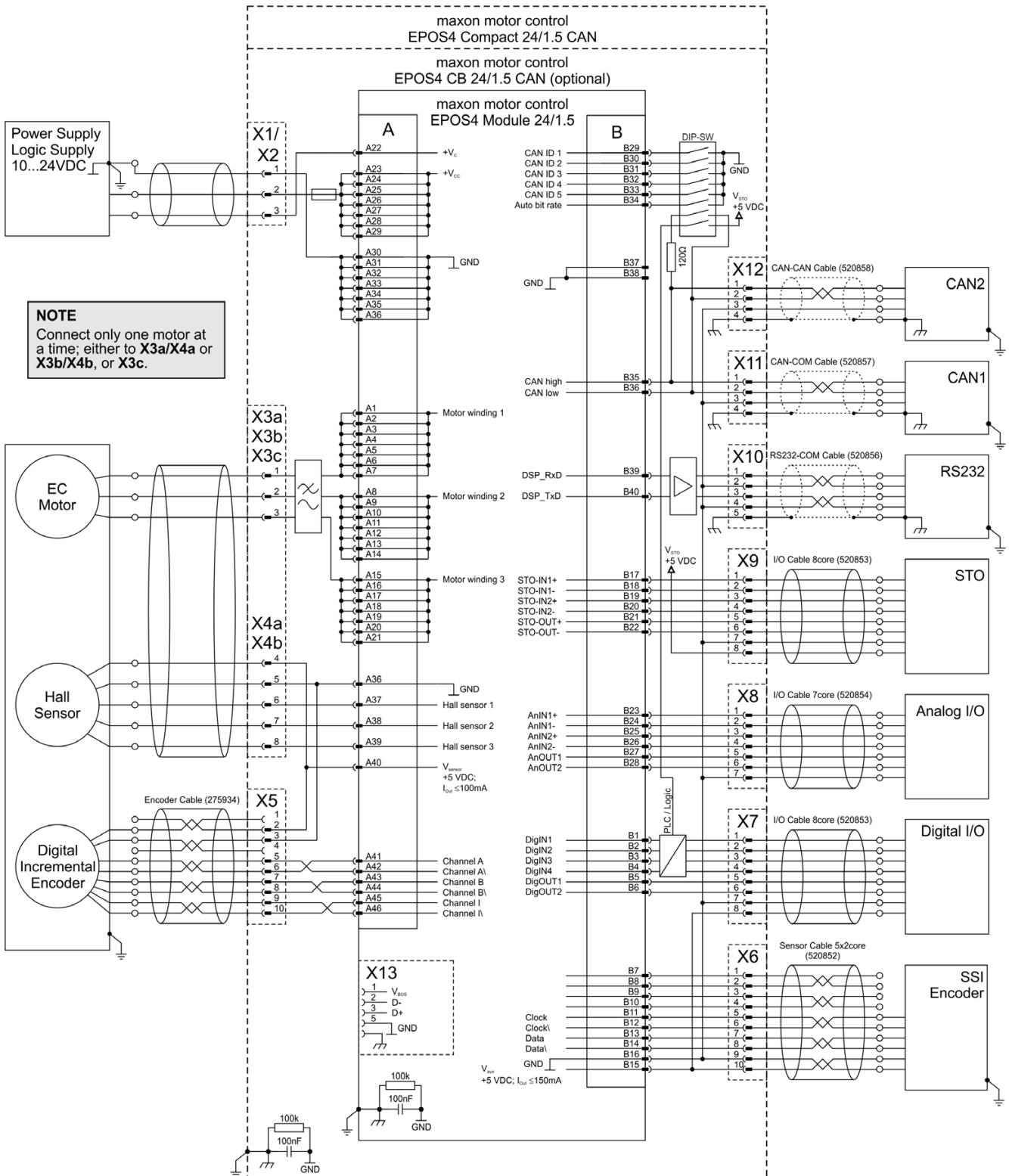


Figure 5-71 EC motor (Hall sensors & digital incremental & SSI encoder)

5.3.8 EC Motor – Digital Incremental & SSI Encoder

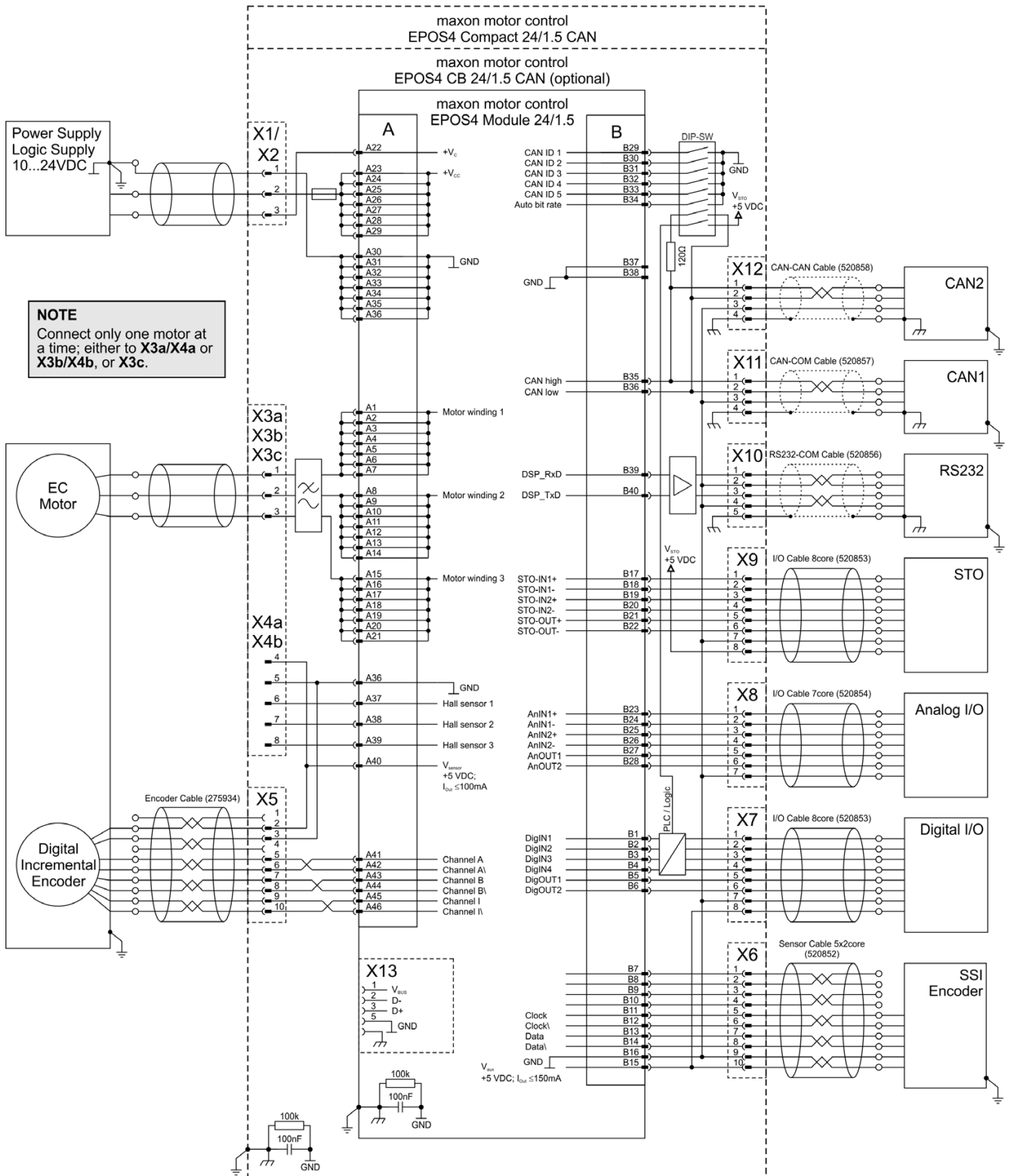


Figure 5-72 EC motor (digital & SSI encoder)

5.3.9 EC Motor – SSI Encoder

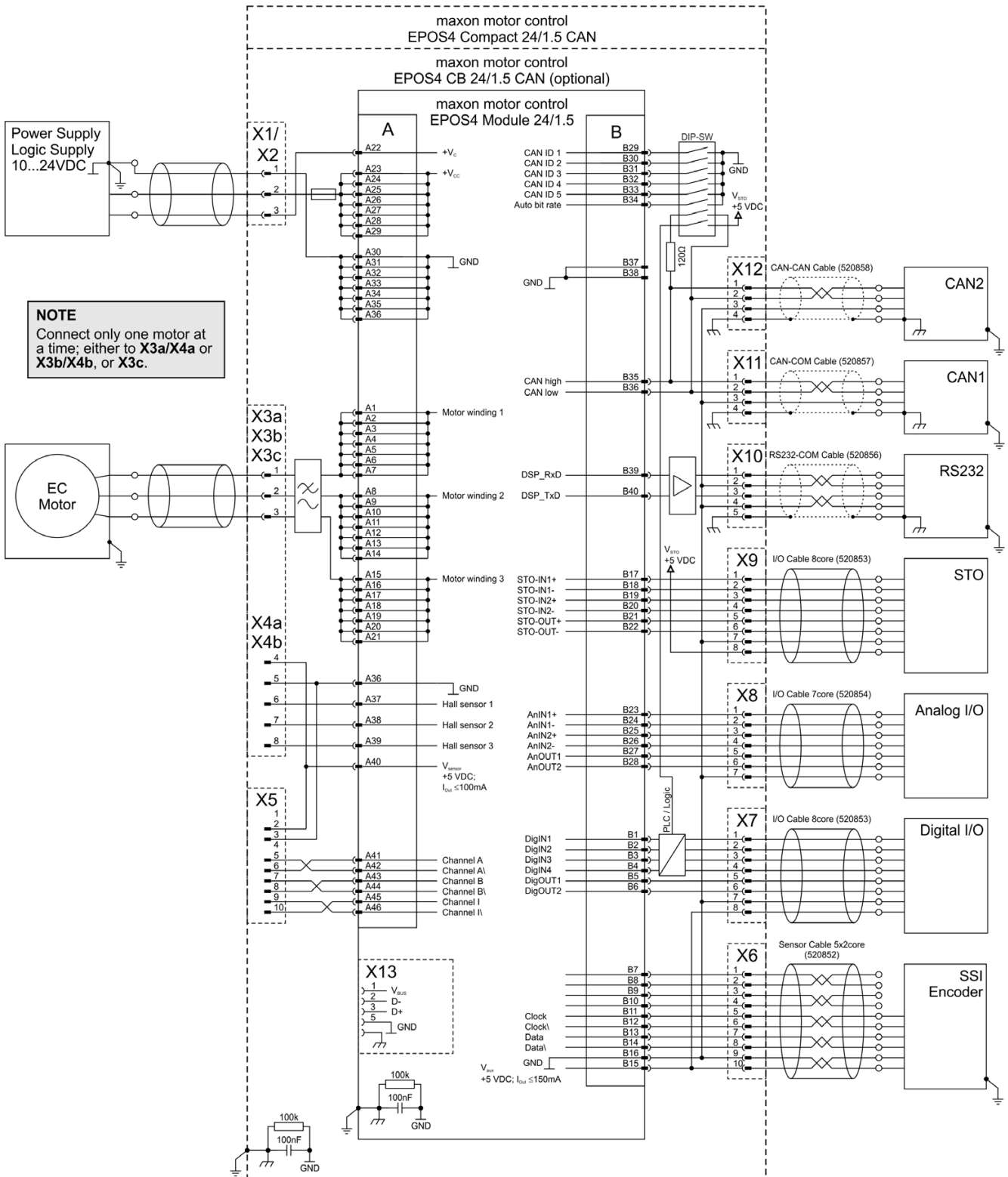


Figure 5-73 EC motor (SSI encoder)

LIST OF FIGURES

Figure 1-1 Documentation structure 5

Figure 1-2 Configuration overview 8

Figure 2-3 Derating of output current 13

Figure 2-4 Power dissipation and efficiency 14

Figure 2-5 EPOS4 Module 24/1.5 – Dimensional drawing [mm] 14

Figure 2-6 EPOS4 CB 24/1.5 CAN – Dimensional drawing [mm] 15

Figure 2-7 EPOS4 Compact 24/1.5 CAN – Dimensional drawing [mm] 15

Figure 3-8 Pin assignment 18

Figure 3-9 EPOS4 CB 24/1.5 CAN (left) / EPOS4 Compact 24/1.5 CAN (right) 21

Figure 3-10 EPOS4 CB 24/1.5 CAN – Connectors 23

Figure 3-11 Power & logic supply connector X1/X2 24

Figure 3-12 Motor & Hall sensors connectors X3a/X4a (left) and X3b/X4b (right) 25

Figure 3-13 Motor connector X3c 27

Figure 3-14 Encoder connector X5 28

Figure 3-15 Sensor connector X6 30

Figure 3-16 Digital I/O connector X7 32

Figure 3-17 Analog I/O connector X8 33

Figure 3-18 STO connector X9 34

Figure 3-19 RS232 connector X10 35

Figure 3-20 CAN 1 connector X11 and CAN 2 connector X12 36

Figure 3-21 Adapter BLACK FPC11poles 37

Figure 3-22 Adapter BLUE FPC8poles 38

Figure 3-23 Adapter GREEN FPC8poles 38

Figure 3-24 EPOS4 CB 24/1.5 CAN – DIP switch SW1 39

Figure 3-25 EPOS4 CB 24/1.5 CAN – Jumper JP1 42

Figure 3-26 Hall sensor 1 input circuit (analogously valid for Hall sensors 2 & 3) 46

Figure 3-27 Encoder input circuit Ch A “differential” (analogously valid for Ch B & Ch I) 48

Figure 3-28 Encoder input circuit Ch A “single-ended” (analogously valid for Ch B & Ch I) 48

Figure 3-29 Digital incremental encoder input circuit Ch A “differential” (analogously valid for Ch B) 50

Figure 3-30 Digital incremental encoder input circuit Ch I 50

Figure 3-31 Digital incremental encoder input circuit Ch A “single-ended” (analogously valid for Ch B) 51

Figure 3-32 Digital incremental encoder input circuit Ch I 52

Figure 3-33 Analog incremental encoder input circuit Ch A “differential” (analogously valid for Ch B) 53

Figure 3-34 Analog incremental encoder input circuit Ch I (digital evaluation) 54

Figure 3-35 SSI absolute encoder data input 55

Figure 3-36 SSI absolute encoder clock output 56

Figure 3-37 HsDigIN1 circuit “differential” (analogously valid for HsDigIN2...4) 57

Figure 3-38 HsDigIN1 circuit “single-ended” (analogously valid for HsDigIN2...4) 58

Figure 3-39 HsDigOUT1 output circuit 59

Figure 3-40 DigIN1 circuit (analogously valid for DigIN2...4) – Module 60

Figure 3-41 DigIN1 circuit (analogously valid for DigIN2...4) – Compact / Logic level setting 61

Figure 3-42 DigIN1 circuit (analogously valid for DigIN2...4) – Compact / PLC level setting 62

Figure 3-43 DigOUT1 circuit (analogously valid for DigOUT2 and Compact) 62

Figure 3-44 DigOUT1 “sinks” (analogously valid for DigOUT2 and Compact) 63

Figure 3-45 DigOUT1 “source” (analogously valid for DigOUT2 and Compact) 63

Figure 3-46 STO-IN1 circuit (analogously valid for STO-IN2) 64

Figure 3-47 STO-OUT circuit 65

Figure 3-48 AnIN1 circuit (analogously valid for AnIN2) 66

Figure 3-49 AnOUT1 circuit (analogously valid for AnOUT2) 67

Figure 3-50 USB connector X13 73

Figure 3-51 Status LED 74

Figure 4-52 Wiring of power supply 76

Figure 4-53 Wiring of logic supply 77

Figure 4-54 Wiring of motor winding 1 (analogously valid also for motor windings 2 & 3) 78

Figure 4-55 Wiring of RS232 transceiver 79

Figure 4-56 SMT footprint [mm] – Top view 82

Figure 5-57 Interfaces – Designations and location 83

Figure 5-58 DC motor (no sensor) 85

Figure 5-59 DC motor (digital incremental encoder) 86

Figure 5-60 DC motor (digital & digital incremental encoder) 87

Figure 5-61 DC motor (digital & analog incremental encoder) 88

Figure 5-62 DC motor (digital incremental & SSI encoder) 89

Figure 5-63 DC motor (analog incremental encoder) 90

Figure 5-64 DC motor (SSI encoder) 91

Figure 5-65 EC motor (Hall sensors) 92

Figure 5-66 EC motor (Hall sensors & digital incremental encoder) 93

Figure 5-67 EC motor (Hall sensors & analog incremental encoder) 94

Figure 5-68 EC motor (Hall sensors & SSI encoder) 95

Figure 5-69 EC motor (Hall sensors & digital & digital incremental encoder) 96

Figure 5-70 EC motor (Hall sensors & digital & analog incremental encoder) 97

Figure 5-71 EC motor (Hall sensors & digital incremental & SSI encoder) 98

Figure 5-72 EC motor (digital & SSI encoder) 99

Figure 5-73 EC motor (SSI encoder) 100

LIST OF TABLES

Table 1-1	Notation used	6
Table 1-2	Symbols and signs	6
Table 1-3	Brand names and trademark owners	7
Table 1-4	Abbreviations	8
Table 2-5	Technical data	12
Table 2-6	Limitations.	14
Table 2-7	Standards	16
Table 3-8	Pin assignment A1...A46 (X1...X5)	18
Table 3-9	Pin assignment B1...B46 (X6...X12)	20
Table 3-10	Prefab maxon cables	22
Table 3-11	EPOS4 Connector Set – Content	22
Table 3-12	Recommended tools.	22
Table 3-13	Power & logic supply connector X1/X2 – Pin assignment	24
Table 3-14	Power & logic supply connector X1/X2 – Specification and accessories	24
Table 3-15	Motor & Hall sensors connectors X3a/X4a / X3b/X4b – Pin assignment for maxon DC motor	25
Table 3-16	Motor & Hall sensors connectors X3a/X4a / X3b/X4b – Pin assignment for maxon EC motor	25
Table 3-17	Motor & Hall sensors connector X3a/X4a – Specification and accessories	26
Table 3-18	Motor & Hall sensors connector X3b/X4b – Specification and accessories	26
Table 3-19	Motor connector X3c – Pin assignment	27
Table 3-20	Motor connector X3c – Specification and accessories	27
Table 3-21	Encoder connector X5 – Pin assignment	28
Table 3-22	Encoder connector X5 – Accessories.	28
Table 3-23	Encoder Cable	29
Table 3-24	Sensor connector X6 – Pin assignment	30
Table 3-25	Sensor Cable 5x2core	31
Table 3-26	Digital I/O connector X7 – Pin assignment	32
Table 3-27	Signal Cable 8core	32
Table 3-28	Analog I/O connector X8 – Pin assignment	33
Table 3-29	Signal Cable 7core	33
Table 3-30	STO connector X9 – Pin assignment	34
Table 3-31	STO Idle Connector	34
Table 3-32	RS232 connector X10 – Pin assignment	35
Table 3-33	RS232-COM Cable.	35
Table 3-34	CAN 1 connector X11/CAN 2 connector X12 – Pin assignment.	36
Table 3-35	CAN-COM Cable	36
Table 3-36	CAN-CAN Cable	36
Table 3-37	Adapters for Flexprint cables	37
Table 3-38	Adapter BLACK FPC11poles – Pin assignment.	37
Table 3-39	Adapter BLUE FPC8poles – Pin assignment	38
Table 3-40	Adapter GREEN FPC8poles – Pin assignment	38
Table 3-41	DIP switch SW1 – Binary code values	39
Table 3-42	DIP switch SW1 – Examples	40

Table 3-43	DIP switch SW1 – CAN automatic bit rate detection	40
Table 3-44	DIP switch SW1 – CAN bus termination	41
Table 3-45	DIP switch SW1 – Digital input level	41
Table 3-46	Jumper JP1 – Power supply for DC motor winding	42
Table 3-47	Spare parts list	42
Table 3-48	Power supply – Pin assignment	43
Table 3-49	Logic supply – Pin assignment	44
Table 3-50	DC motor – Pin assignment	45
Table 3-51	EC motor – Pin assignment	45
Table 3-52	Hall sensor – Pin assignment	46
Table 3-53	Encoder – Pin assignment	47
Table 3-54	Incremental encoder – Pin assignment	49
Table 3-55	SSI absolute encoder – Pin assignment	55
Table 3-56	High-speed digital I/Os – Pin assignment	57
Table 3-57	Digital I/Os – Pin assignment – Module	60
Table 3-58	Digital I/Os – Pin assignment – Compact	61
Table 3-59	STO I/Os – Pin assignment	64
Table 3-60	STO logic state	65
Table 3-61	Analog I/Os – Pin assignment	66
Table 3-62	SCI – Pin assignment	68
Table 3-63	RS232 – Pin assignment	69
Table 3-64	CAN bus line / CAN 1 / CAN 2 – Pin assignment	70
Table 3-65	CAN ID – Pin assignment	71
Table 3-66	CAN ID – Examples	71
Table 3-67	SPI – Pin assignment	72
Table 3-68	USB connector X13 – Pin assignment	73
Table 3-69	USB Type A - micro B Cable	73
Table 3-70	Status LED	74
Table 4-71	Motherboard Design Guide – Recommended components	80
Table 4-72	Motherboard Design Guide – Grounding	81

INDEX

A

abbreviations used **8**
 adapters, see “cables (prefab)”
 alerts **6**
 analog incremental encoder (differential) **53**
 analog inputs **66**
 analog outputs **67**
 applicable EU directive **17**
 applicable regulations **10**

B

bit rate detection **40, 72**
 bit rate, default **70**
 BLDC motor
 adapters for maxon EC motor **37**
 connection **18, 45**
 wiring diagram **92**

C

C1 (capacitor) **76**
 cables (prefab)
 Adapter BLACK FPC11poles **37**
 Adapter BLUE FPC8poles **38**
 Adapter GREEN FPC8poles **38**
 CAN-CAN Cable **36**
 CAN-COM Cable **36**
 Encoder Cable **29**
 RS232-COM Cable **35**
 Sensor Cable 5x2core **31**
 Signal Cable 7core **33**
 Signal Cable 8core **32**
 STO Idle Connector **34**
 USB Type A - micro B Cable **73**
 CAN bus termination **41, 70**
 CAN ID **39, 71**
 CAN interface **70**
 choke, motor **77**
 connectors
 X1/X2 **24**
 X3a/X4a **25**
 X3b/X4b **25**
 X3c **27**
 X5 **28**
 X6 **30**
 X7 **32**
 X8 **33**
 X9 **34**
 X10 **35**
 X11 **36**
 X12 **36**
 X13 **73**
 country-specific regulations **10**

D

D1 (DVS diode) **76**
 D2 (DVS diode) **77**
 DC motor
 connection **18, 45**
 wiring diagram **85**
 device condition, display of **74**
 digital high-speed inputs (differential) **57**
 digital high-speed inputs (single-ended) **58**
 digital high-speed output **59**
 digital incremental encoder (differential) **49**
 digital incremental encoder (single-ended) **51**
 digital inputs **60**
 digital outputs **62**
 DIP switch SW1 **39**

E

EC motor
 adapters for maxon EC motor **37**
 connection **18, 45**
 wiring diagram **92**
 encoders
 absolute **55**
 differential **47**
 incremental **49**
 serial **55**
 single-ended **48**
 EPOS4 Connector Set **22**
 ESD **10**
 EU directive, applicable **17**

F

FPC adapters **37**
 FU1 (input fuse) **76**

H

Hall sensor **46**
 how to
 calculate the required supply voltage **43**
 choose an adapter for flexprint cable **37**
 get help in designing the motherboard **75**
 interpret icons (and signs) used in this document **6**

I

incorporation into surrounding system **17**
incremental encoder **49**
informatory signs **6**
inputs
 analog **66**
 digital **60**
 high-speed digital **57**
 STO **64**
interfaces
 CAN **36, 70**
 location and designation **83**
 RS232 **35, 68**
 SCI **68**
 SPI **72**
 USB **73**
internal motor chokes **77**

J

JP1 **42**
jumpers **42**

L

LEDs, interpretation of **74**
logic supply **44**

M

mandatory action signs **6**
motor choke **77**
motor types, supported **8**

N

naming of components **8**
Node Address **39, 71**
notations used **6**

O

operating license **17**
outputs
 analog **67**
 digital **62**
 high-speed digital **59**
 STO **65**

P

part numbers
 275934 **29**
 403968 **73**
 418719 **37**
 418721 **37**
 418723 **37**
 520852 **31**
 520853 **32**
 520854 **33**
 520856 **35**
 520857 **36**
 520858 **36**
 520859 **22**
 520860 **34**
 536630 **11**
 536997 **21**
 546714 **11, 21**
 590736 **24**
 590737 **26**
 590738 **80**
performance data **11**
pin assignment **18**
power supply **43**
precautions **10**
prerequisites prior installation **17**
prohibitive signs **6**
protective measures (ESD) **10**
purpose
 of the device **8**
 of the document **5**

R

regulations, applicable **10**
RS232 transceiver **79**

S

Safe Torque Off (STO) **64**
safety alerts **6**
safety first! **10**
SCI (Serial Communication Interface) **68**
Serial Communication Interface (SCI) **68**
serial encoder **55**
signs used **6**
SPI (Serial Peripheral Interface) **72**
SSI absolute encoder **55**
standards, fulfilled **16**
status LEDs **74**
STO (Safe Torque Off) **64**
supply voltage, required **43**
SW1 **39**
symbols used **6**

T

technical data **11**
termination (CAN bus) **41, 70**

U

USB port **73**

W

wiring diagrams
 BLDC motors **92**
 DC motors **85**
 EC motors **92**
wiring examples
 additional inductance on Motherboard **78**
 DigOUT **63**



EtherCAT® is a registered trademark and patented technology, licensed by Beckhoff Automation GmbH, Germany

© 2018 maxon motor. All rights reserved.

The present document – including all parts thereof – is protected by copyright. Any use (including reproduction, translation, microfilming, and other means of electronic data processing) beyond the narrow restrictions of the copyright law without the prior approval of maxon motor ag, is not permitted and subject to prosecution under the applicable law.

maxon motor ag

Brünigstrasse 220
P.O.Box 263
CH-6072 Sachseln
Switzerland

Phone +41 41 666 15 00

Fax +41 41 666 16 50

www.maxonmotor.com