

The EC 32 flat with integrated electronics is a brushless, speed-controlled 1-quadrant drive. It is available as 15 watt version and in 2-wire or 5-wire variants as follows:

Order number		Variant	Nominal speed [rpm]	Output [W]
IP 40	IP 00			
353400	353324	2-wire	3000	15
353401	353325	2-wire	6000	15
353399	349801	5-wire «Enable»	6000	15
370418	370417	5-wire «CW/CCW»	6000	15

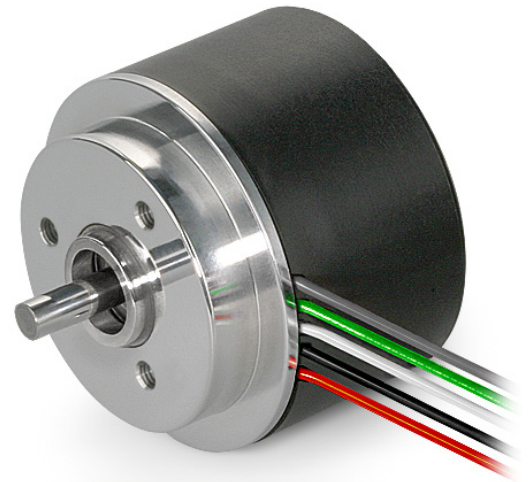

Functions

- Commutation with Hall sensors
- Digital speed control
- Speed range: 200...7'000 rpm (depending on variant)
- Current limitation, non-adjustable
- Overvoltage and undervoltage switch-off
- Overvoltage protection
- Blockage protection, temperature monitoring
- Inverse polarity protection

2-wire variant

- Speed proportional to supply voltage

5-wire variant

- Set value speed through analog signal 0...10 V
- 2-wire operation possible
- Versions:
 - «Enable» TTL level-compatible
 - Direction preselection «CW/CCW» TTL level-compatible
- Speed monitor delivers speed-proportional frequency signal

Contents

READ THIS FIRST	2
1 Technical Data	3
2 Installation	6
3 Minimal Wiring	7
4 Functional Description of 2-Wire Variant	10
5 Functional description of 5-Wire Variant	11
6 Protective Functions	15
7 Troubleshooting	16

READ THIS FIRST

These instructions are intended for qualified technical personnel.

Prior commencing with any activities...

- you must carefully read and understand this manual and
- you must follow the instructions given therein.

The EC 32 flat with integrated electronics is considered as partly completed machinery according to EU Directive 2006/42/EC, Article 2, Clause (g) and **is intended to be incorporated into or assembled with other machinery or other partly completed machinery or equipment.**

Therefore, you must not put the device into service,...

- unless you have made completely sure that the other machinery – the surrounding system the device is intended to be incorporated to – fully complies with the requirements stated in the EU directive 2006/42/EC!
- unless the surrounding system fulfills all relevant health and safety aspects!
- unless all respective interfaces have been established and fulfill the stated requirements!

Safety Guidelines

Qualified personnel

Do not engage with any work unless you possess the necessary skills.

Legal requirements

Observe any regulation applicable in the country and/or at the site of implementation with regard to health and safety/accident prevention and/or environmental protection.

Make sure that all associated devices and components are installed according to local regulations.

Additional safety equipment

Be aware that, by principle, an electronic apparatus can not be considered fail-safe. Therefore, you must make sure that any machine/apparatus has been fitted with independent monitoring and safety equipment. If the machine/apparatus should break down, if it is operated incorrectly, if the control unit breaks down or if the cables break or get disconnected, etc., the complete drive system must return – and be kept – in a safe operating mode.

Repairs

Be aware that you are not entitled to perform any repair on components supplied by maxon motor.

Danger to life

Touching live wires causes death or serious injuries!

- Consider any power cable as connected to live power, unless having proven the opposite!
- Make sure that neither end of cable is connected to live power!
- Make sure that power source cannot be engaged while work is in process!
- Obey lock-out/tag-out procedures!
- Make sure to securely lock any power engaging equipment against unintentional engagement and tag it with your name!

Max. supply voltage

The connected supply voltage must be between 10 VDC and 28 VDC. Permanently applied voltages above 30 VDC will destroy the unit.

Electrostatic sensitive components

The built-in electronics may be destroyed by externally applied electronic discharge during transport, installation, and during operation.

- Make sure to wear working cloth in compliance with ESD.
- Handle device with extra care.
- Limit the voltage between flange and live parts to 500 VDC.

Temperature

During operation, the temperature of housing, flange, or other components may exceed 60°C.

Terms used

1-Q speed controller	The motor produces positive torque in the selected or programmed direction. The load is not actively decelerated when the speed set value is reduced or the direction changed (direction preselection version). Speed control recommences as soon as the load has reduced its speed by friction to the level specified by the set value speed.
Max. torque M_{max} [mNm]	The maximum torque the motor can produce for a short term. It is limited by the overload protection of the electronics.
Max. current I_{max} [A]	Supply current with which the peak torque is generated at nominal voltage. With an active speed controller, the supply current is not proportional to the torque, but also depends on the supply voltage. As a result, this value only applies at nominal voltage.
IP 00	No protection against access to dangerous parts. No protection against water.
IP 40	Protected against access to dangerous parts with a wire, tool or similar. $\geq \varnothing 1$ mm and against foreign objects $\geq \varnothing 1$ mm. No protection against water.
Direction CW/ CCW	As seen towards the mounting flange: <ul style="list-style-type: none"> • CW = shaft turns to the right (clockwise) • CCW = shaft turns to the left (counterclockwise)

1 Technical Data



All data in the document are typical values.

Motor Data 15 Watt at 24 VDC				
IP 40 (with housing) IP 00 (without housing)		353400 353324	353401 353325	353399 / 370418 349801 / 370417
Nominal voltage	VDC	24	24	24
No load speed	rpm	3000	6000	6000
No load current	mA	43	86	86
Nominal speed	rpm	3000	6000	6000
Nominal torque	mNm	26.2	24	24
Nominal current	mA	590	950	950
Max. Torque	mNm	34.4	34	34
Max. current	mA	1200	1600	1600
Max. efficiency	%	54	64	64

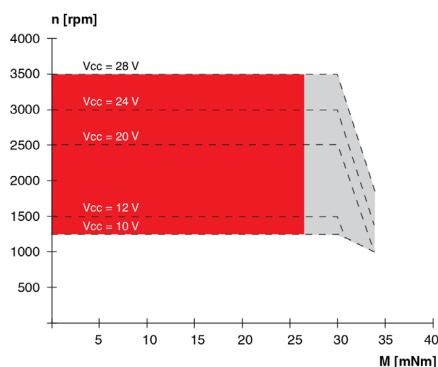

Operating range $n = f(M)$
Nominal speed 3000 rpm

Figure 1 2-Wire Variant (353324) (353400)

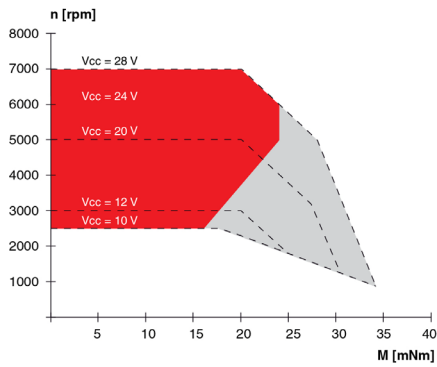

Operating range $n = f(M)$
Nominal speed 6000 rpm

Figure 2 2-Wire Variant (353325) (353401)

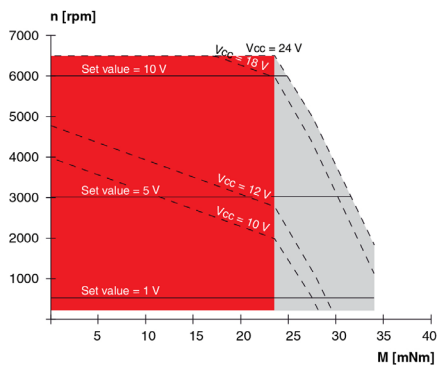

Operating range $n = f(M)$
Torque and speed depend on operating voltage

Figure 3 5-Wire Variant (349801) (353399) (370417) (370418)

Controller Data				
Variant		2-wire	2-wire	5-wire
Nominal speed		3000 rpm	6000 rpm	6000 rpm
Control variable		Speed	Speed	Speed
Supply voltage V_{CC}	V	10...28	10...28	10...28
Input set value speed	V	=VCC	=VCC	0.33...10.8
Scaling set value speed	rpm/V	125	250	600
Speed range	rpm	1250...3500	2500...7000	200...6480
Max. acceleration	rpm/s	3000	6000	6000
Direction of rotation		CW	CW	CW
Version Direction Preselection «CW/CCW»		-	-	CW/CCW

Thermal Data		
Version		15 Watt
Thermal resistance housing/ambient air	K/W-1	7.6
Thermal resistance winding/housing	K/W-1	5.9
Thermal time constant winding	s	10.3
Thermal time constant motor	s	72.6
Max. winding temperature	°C	+125
Max. temperature of electronics	°C	+105

Mechanical Data (preloaded ball bearings)			
Version			15 Watt
Rotor inertia		gcm ²	35
Axial play at axial load	<2 N	mm	0
	>2 N		0.14
Radial play			preloaded
Max. axial load	dynamic	N	6.8
Max. axial load	static supported *a	N	70 1000
Max. radial load *b		N	32
Motor weight		g	91
*a Static load with supported shaft			
*b Admissible load 7.5 mm from flange			

Electrical Connections			
Wire	Description	Connection	Value
red	Supply voltage V _{CC}	Supply	10...28 VDC
black	GND	Supply	Ground
white (5-wire operation only)	Input set value speed	Input	0.33...10.8 VDC
green (5-wire operation only)	Monitor speed n	Output	6 counts per turn
Version Enable grey (5-wire operation only)	«Enable»	Input	2.4...28 VDC
Version Direction Preselection grey (5-wire operation only)	«CW/CCW»	Input	2.4...28 VDC
Cross section			AWG24 = 0.22 mm ²

Protective Functions	
Inverse polarity protection	up to max. 30 VDC
Blockage protection	cut off with blocked motor after 2 s
Undervoltage	cut off at V _{CC} < 8.5 V
Overvoltage protection	cut off at V _{CC} > 29.5 V
Thermal monitoring of power stage	cut off at (typical) at T > 100 °C
Overvoltage protection (transient)	150 mWs

Ambient Conditions	
Temperature operation	-40...+40°C
Temperature operation with reduced power output	+40...+85°C
Temperature storage	-40...+85°C
Humidity (condensation not permitted)	20...80%

Voltage Supply	
Ripple	<5%
Load-dependent output current (recommended)	≥1 A
Output current	min. 9.5 VDC max. 29 VDC

Dimensional Drawings

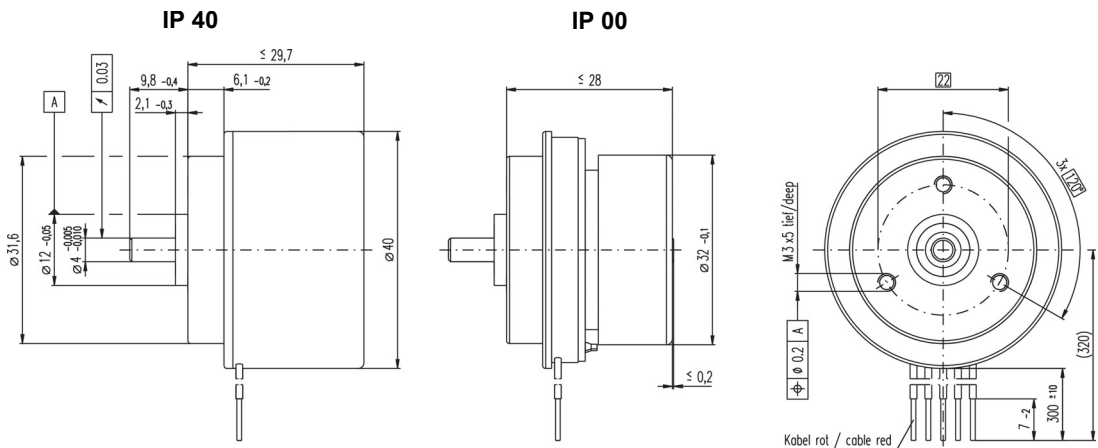

Figure 4 15 Watt Version – Dimensional Drawing [mm]

2 Installation



Electrostatic Sensitive Device (ESD)

- Make sure to wear working cloth in compliance with ESD.
- Handle device with extra care.



Possible irreversible Damage of Motor

- Until completion of the installation, individual components can be permanently damaged by improper handling. Therefore, handle the components with particular care.
- Max. torque of flange screws is 1.1 Nm (grade 8.8 screws).
- Improved cooling through mounting a large metallic part.
- Cable outlet preferably downwards.

EMC-compliant Installation

Cable length ≤ 300 mm:

- Usually, no shielding is required.
- Star wiring recommended if several EC 32 flat with integrated electronics are supplied by a common power supply.

Cable length > 300 mm:

- The voltage drop in the connection cable must be minimized by choosing a sufficiently large wire cross section.
- In electromagnetically harsh environments, use of shielded cables connected to ground at both ends can improve immunity against interferences.
- Release cable shielding on one side if 50/60 Hz interference problems occur.
- The incidence surface for interferences can be reduced by shortening the unshielded original connection cable.
- Immunity against interferences and speed stability in case of fluctuating loads can be accomplished by routing the set speed value signal separately in a shielded cable that is put to ground on both sides. In addition to the set speed value signal, a second ground (GND) line must also be carried in this separate cable, but only connected on the motor side. The external set value speed signal must be potential-free.

3 Minimal Wiring

2-Wire Variant

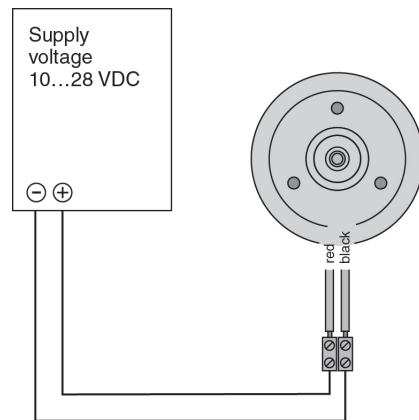

Figure 5 2-Wire Variant with external Power Source

5-Wire Variant

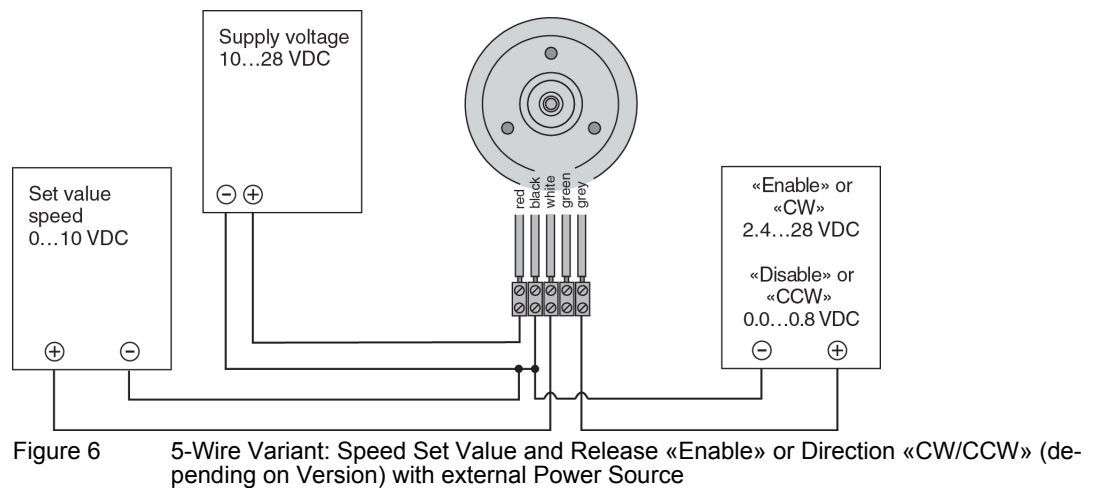

Figure 6 5-Wire Variant: Speed Set Value and Release «Enable» or Direction «CW/CCW» (depending on Version) with external Power Source

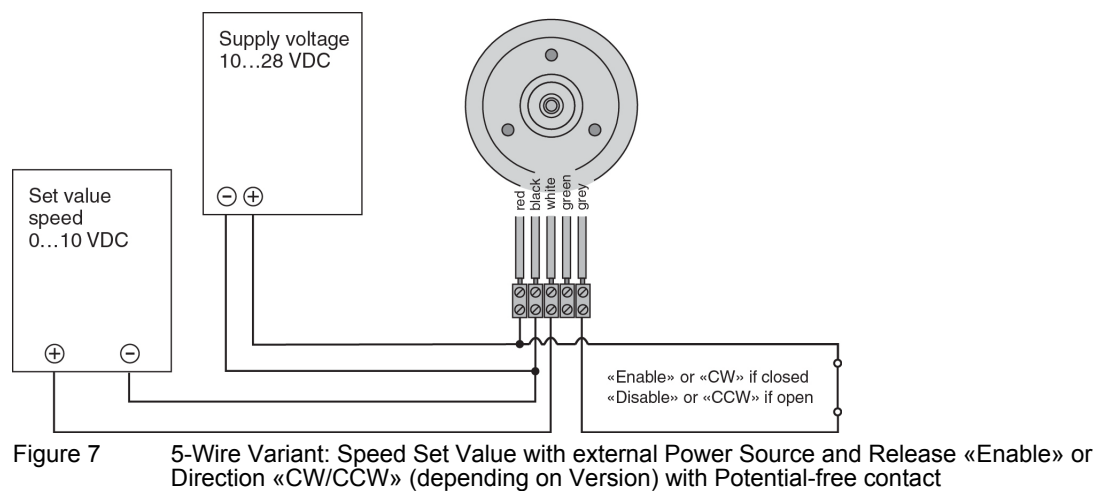

Figure 7 5-Wire Variant: Speed Set Value with external Power Source and Release «Enable» or Direction «CW/CCW» (depending on Version) with Potential-free contact

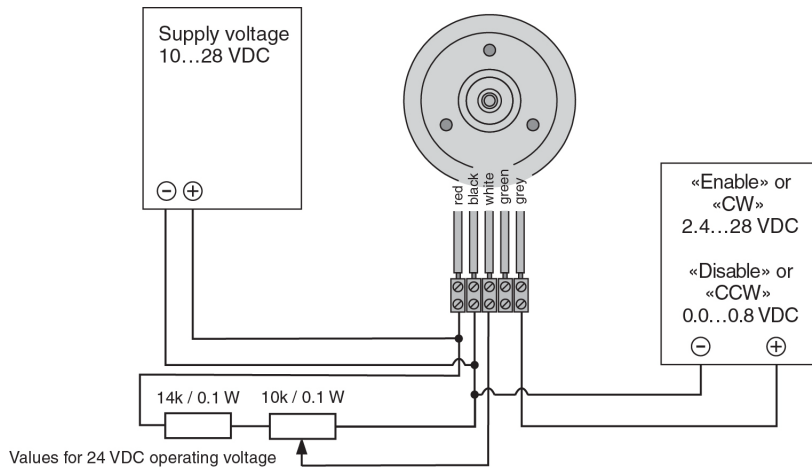

Figure 8 5-Wire Variant: Speed Set Value with external Potentiometer and Release «Enable» or Direction «CW/CCW» (depending on Version) with external Power Source

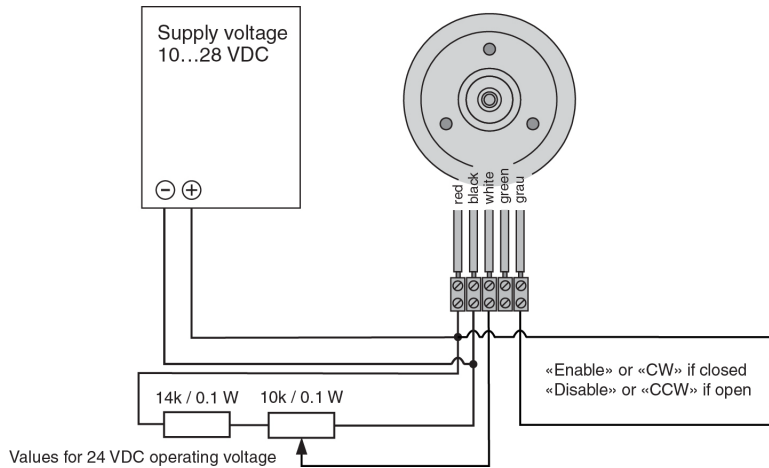

Figure 9 5-Wire Variant: Speed Set Value with external Potentiometer and Release «Enable» or Direction «CW/CCW» (depending on Version) with Potential-free Contact

5-Wire Variant in Operating Mode “2-Wire”

The operating mode “2-Wire” can be simulated by shorting the connections of speed set value input and speed monitor output. Thereby, the speed proportional to the supply voltage (→ Figure 17).

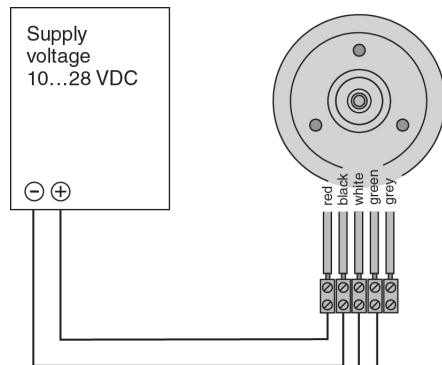

Figure 10 5-Wire in Operating Mode “2-Wire”

With the variant Direction Preselection «CW/CCW», the grey wire is used to define direction of rotation.

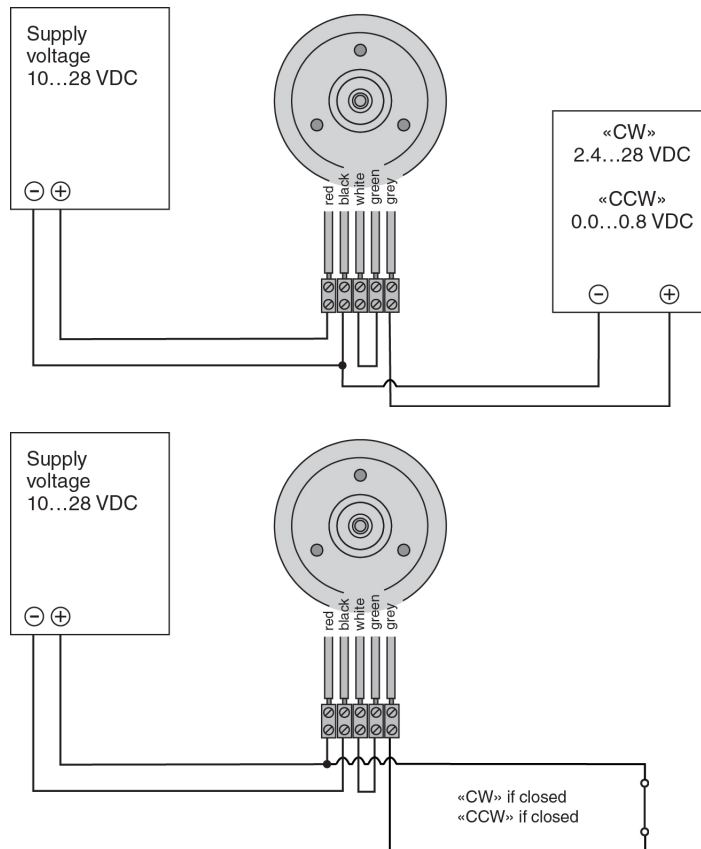

Figure 11 5-Wire Variant: Direction «CW/CCW» in Operating Mode “2-Wire”

4 Functional Description of 2-Wire Variant

Speed proportional to supply voltage V_{CC}

- Motor speed is proportional to the supply voltage, independent of torque.
- Supply voltage can be varied within the permitted range.
- Speed at 24 V supply voltage is:
 - 3000 rpm (353324) (353400)
 - 6000 rpm (353325) (353401)

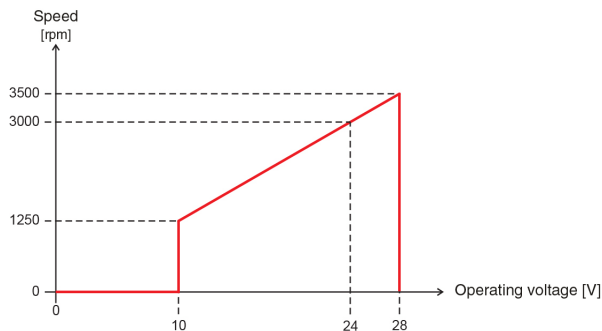

Figure 12 2-Wire Variant: Speed 3000 rpm as Function of the applied Supply Voltage

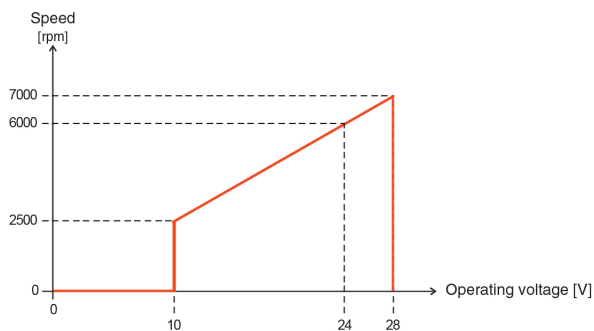

Figure 13 2-Wire Variant: Speed 6000 rpm as Function of the applied Supply Voltage

5 Functional description of 5-Wire Variant

Set value speed input

Motor speed is set with an analog voltage at the input “Speed Set Value”. The input is protected against overvoltage.

Pin assignment	Connection wire white
Input voltage range	0...+10.8 V (referenced to GND)
Input impedance	62 kΩ (in range of 0...+21.9 V) 47 kΩ (in range of +21.9...+30 V)
Continuous overvoltage protection	-30...+30 V

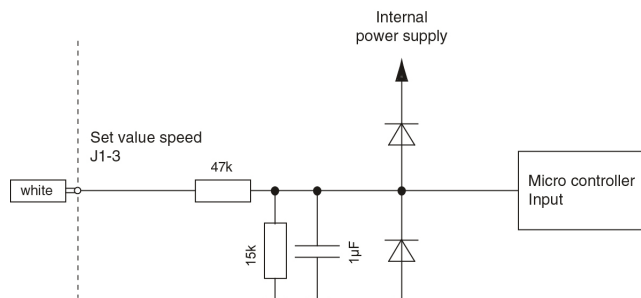

Figure 14 5-Wire Variant: Internal Circuitry of Input “Speed Set Value”

The speed set value is set with the voltage at the input “Speed Set Value”. The set speed is controlled by the controller. Changes to speed set value are restricted by the maximum acceleration (→ Controller Data on page 4).

To activate the power stage in the «Enable» version, the voltage at the input “Enable” must be higher than 2.4 V, while the speed set value must be above 0.17 V.

With the «CW/CCW» version, the power stage is activated when the speed set value is above 0.17 V.

Set Value	Function	Remarks
0...0.17 V	«Disable»	Power stage disabled
0.17...0.33 V	Operation at minimal speed (200 rpm)	If «Enable» higher than 2.4 V (version «Enable»)
0.33...10.8 V	Linear speed setting between 200 and 6480 rpm $V_{aim} = \frac{n_{aim}}{600}$	In speed range 200...300 rpm, regulation accuracy of the speed controller is limited. The speed may considerably differ from the set value depending on load and supply voltage.

V_{Soll} Set value voltage

n_{Soll} Desired speed

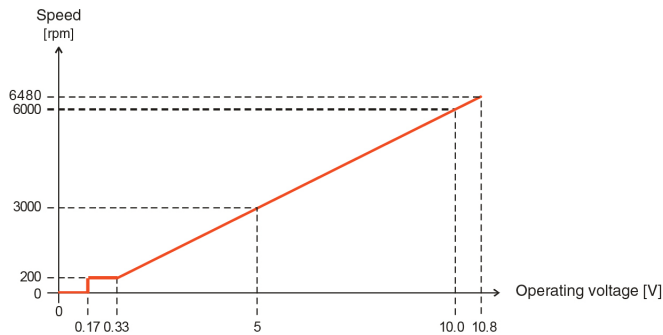

Figure 15 5-Wire Variant: Speed as Function of Set Value Voltage

Optionally, the controller can be set to 2-wire operation mode by linking (shorten) both connections speed monitor (green) and speed set value (white). Thereby, the connection must be established before applying the supply voltage.



Working Principle of Detection of “2-Wire” Operating Mode with 5-Wire Motor

After power on of the controller, the output “Speed Monitor” will be turned on after 270 ms, than turned off again after 40 ms. If the input “Speed Set Value” follows this regime via short circuit, the operating mode “2-wire” will be activated. Thereby, for both measurements, the input “Speed Set Value” must be once above and once below 2.5 V. A fixed random or increasing speed set value upon power on is permitted.

In order not to interfere with detection of “2-wire” operating mode, the motor must neither be externally propelled during power on nor be in rundown.



Setting Speed Set Value by PWM Signal

The speed set value can be preset by fixed frequency and amplitude.

The desired set speed value change is obtained by variation of the duty cycle in range of 0...100%. Both, amplitude and duty cycle thereby have an effect on the resulting speed. The average of the applied PWM voltage corresponds to the analog input signal of the speed set value.

In order to prevent the controller to change to “2-wire” operating mode after power on, the speed set value voltage must not exceed 2.5 V 270 ms after power on and may not be below 2.5 V for another 40 ms. A fixed random or increasing speed set value upon power on is permitted.

Nominal value amplitude PWM set value	0...10.8 V
Max. value amplitude PWM set value	-30...+30 V
Frequency range PWM set value	500 Hz...20 kHz
Modulation PWM set value	0...100%
Continuous overvoltage protection	-30...+30 V

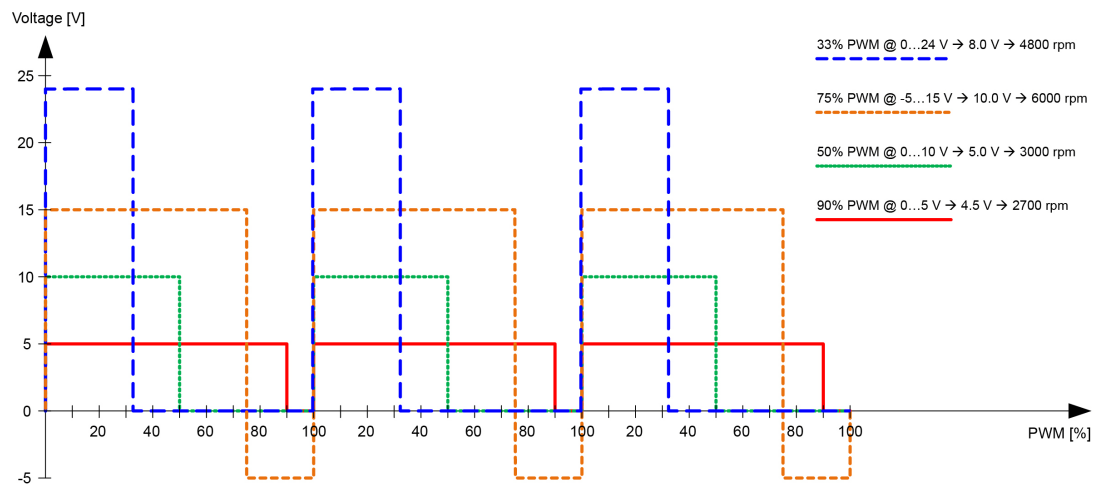

Figure 16 5-Wire Variant: Examples for possible PWM Level Control at Input “Speed Set Value”

Enabling with Version «Enable»

The power stage is activated with the digital input “Enable”. It is protected against overvoltage.

Pin assignment	Connection wire grey
Input voltage range	0...+5.0 V (referenced to GND)
Input impedance	112 kΩ (in range of 0...+5.9 V) 12 kΩ (in range of +5.9...+30 V)
Continuous overvoltage protection	-30...+30 V

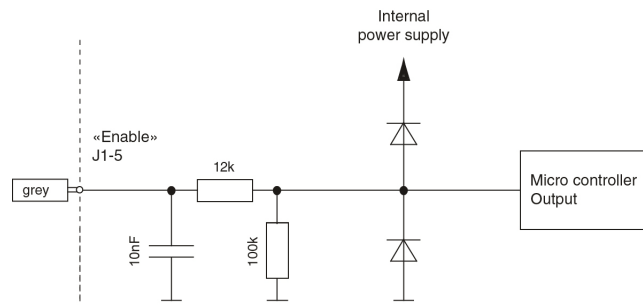

Figure 17 5-Wire Variant: Internal Circuitry of Input “Enable”

The power stage is activated by a voltage above 2.4 V at the input “Enable”. The resulting speed is dependable on the voltage applied to the input “Speed Set Value”.

The power stage is deactivated by a voltage below 0.8 V at the input “Enable”. The motor runs out freely independent of the voltage applied to the input “Speed Set Value”.

Input Voltage	Function	Remarks
0...0.8 V	«Disable»	Power stage disabled
2.4...5.0 V	«Enable»	Power stage enabled, if set value is above 0.17 V

Enabling and Direction Preselection with Version «CW/CCW»

The power stage is activated if the voltage to the input “Speed Set Value” is above 0.17 V. Direction of rotation «CW/CCW» will be determined by digital input “Direction”.

Pin assignment	Connection wire grey
Input voltage range	0...+5.0 V (referenced to GND)
Input impedance	112 kΩ (in range of 0...+5.9 V) 12 kΩ (in range of +5.9...+30 V)
Continuous overvoltage protection	-30...+30 V

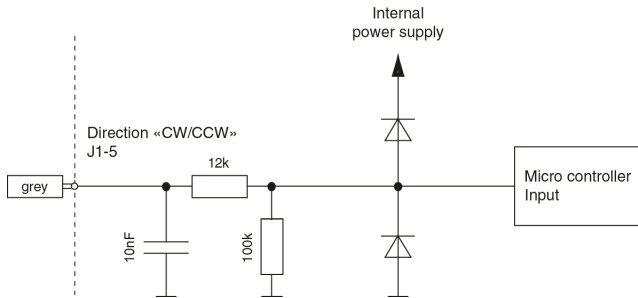

Figure 18 5-Wire Variant: Internal Circuitry of Input “Direction”

The direction of rotation «CW» will be activated by a voltage above 2.4 V. The speed is dependent on the voltage at the input “Speed Set Value”. If the direction of rotation is changed during operation, the motor runs down freely until reaching minimal speed, then accelerates in opposite direction of rotation. The power stage will be deactivated with a voltage below 0.17 V at the speed set value input. The motor runs down freely.

Input Voltage	Function	Remarks
0...0.8 V	Direction of rotation «CCW»	Motor turns in direction «CCW»
2.4...5.0 V	Direction of rotation «CW»	Motor turns in direction «CW»

Speed monitor «Monitor n»

The actual speed of the motor shaft can be monitored at the output “Speed Monitor”. It is available as digital signal (High/Low) and delivers 6 pulses per mechanical turn.

The output “Speed Monitor” is also available in «Disable» state.

Pin assignment	Connection wire green
Voltage output range	0...+5.0 V (referenced to GND)
Output resistance	4.1 kΩ
Low level	max. 0.5 V (without load)
High level	min. 4.2 V (without load)
Duty cycle	50%
Continuous overvoltage protection	-30...+30 V
Frequency at speed monitor output	$f_{monitor} = \frac{n_{actual}}{10}$ $n_{actual} = 10 \cdot n$

$f_{Monitor}$ Frequency at speed monitor output [Hz]

n_{ist} Speed [rpm]

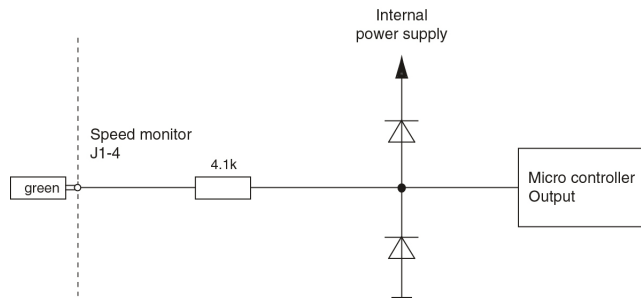

Figure 19 5-Wire Variant: Internal Circuitry of Output "Speed Monitor"

6 Protective Functions

- Inverse polarity protection** The supply voltage V_{CC} is protected against polarity reversal. Thereby, the negative input voltage must not exceed the maximum permitted supply voltage V_{CC} .
- Undervoltage switch-off** The power stage is switched off when the supply voltage V_{CC} drops below approx. 8.5 V to prevent operation beyond the specified range.
If the supply voltage exceeds the restart threshold of approx. 9 V, the EC 32 flat will be again ready for operation.
- Overvoltage switch-off** The power stage is switched off when the supply voltage V_{CC} exceeds approx. 29.5 V to prevent operation beyond the specified range.
If the supply voltage drops below the restart threshold of approx. 28.5 V, the EC 32 flat will be again ready for operation.
- Overvoltage protection** The overvoltage protection comprises a bidirectional Transzorb diode (overvoltage protection diode) capable of receiving a maximum peak energy of 150 mWs. Continuous power loss is 1 W. Threshold voltage is a minimum of 31.1 V, independent of polarity.
- Blockage protection** The power stage is switched off when the rotor is continuously blocked for 2 seconds.
After 4 seconds, the EC 32 flat automatically executes a starting attempt.
- Temperature monitoring** The power stage is switched off if the PCB temperature exceeds approx. 100°C. As soon as the PCB temperature has dropped below approx. 90°C, the EC 32 flat will be again ready for operation.
The electronics' temperature protection can only safeguard the winding if the flange does not dissipate too much heat and an if the winding does not induce heat accumulation.
- Current limiting** The winding current is electronically limited to approx. 1.6 A. Therefore, the maximum load torque is limited accordingly.
If the motor shaft comes to a standstill due to activated current limiting, blockage protection engages after 2 seconds.

7 Troubleshooting

2-Wire Variant

- Supply voltage between 10.0 and 28.0 VDC?
- Supply voltage connected to red and black wires and switched on?
- Voltage at red motor connection positive compared to black connection?
- Power source not in current limiting?
- Motor not blocked mechanically?

5-Wire Variant

- Supply voltage between 10.0 and 28.0 V?
- Supply voltage connected to red and black wires and switched on?
- Voltage at red motor connection positive compared to black connection?
- Speed set value voltage between 0.33 and 10.0 V?
- Speed set value voltage connected to white and black wires and switched on?
- Voltage at white connection positive compared to black connection?
- **Activation via voltage source** (version «Enable» only)
 - Enable voltage between 2.4 and 28.0 VDC?
 - Enable voltage connected to grey and black wires and switched on?
 - Voltage at grey connection positive compared to black connection?
- **Activation via potential-free contact** (version «Enable» only)
 - Grey enable wire directly interconnected with red supply voltage connection?
 - Grey enable wire connected via switch with red supply voltage connection?
 - Switch or contact closed?
- Power source not in current limiting?
- Motor not blocked mechanically?
- Green wire need not necessarily be connected.

5-Wire Variant in Operating Mode “2-Wire”

- White and green wires directly interconnected (short-circuit)?
- Direct interconnection of white and green wire established prior connecting to supply voltage?
- No further connections to green and white wires?
- Supply voltage between 10.0 and 28.0 VDC?
- Supply voltage connected and switched on?
- Voltage at red motor connection positive compared to black connection?
- With version «Enable»: Grey wire need not necessarily be connected.
- With version «CW/CCW»: Grey wire may be used for direction of rotation (→5-Wire Variant in Operating Mode “2-Wire” on page 9).
- Power source not in current limiting?
- Motor not blocked mechanically?

••page intentionally left blank••

© 2017 maxon motor. All rights reserved.

The present document – including all parts thereof – is protected by copyright. Any use (including reproduction, translation, microfilming, and other means of electronic data processing) beyond the narrow restrictions of the copyright law without the prior approval of maxon motor ag, is not permitted and subject to prosecution under the applicable law.

maxon motor ag

Brünigstrasse 220
P.O.Box 263
CH-6072 Sachseln
Switzerland

Phone +41 41 666 15 00

Fax +41 41 666 16 50

www.maxonmotor.com